

THE CENTER  
FOR DIGITAL  
HUMANITIES  
@PRINCETON

# Design

*Visual Language and Typography*

Xinyi Li  
xinyili@princeton.edu

**What is *design***

# Design Disciplines

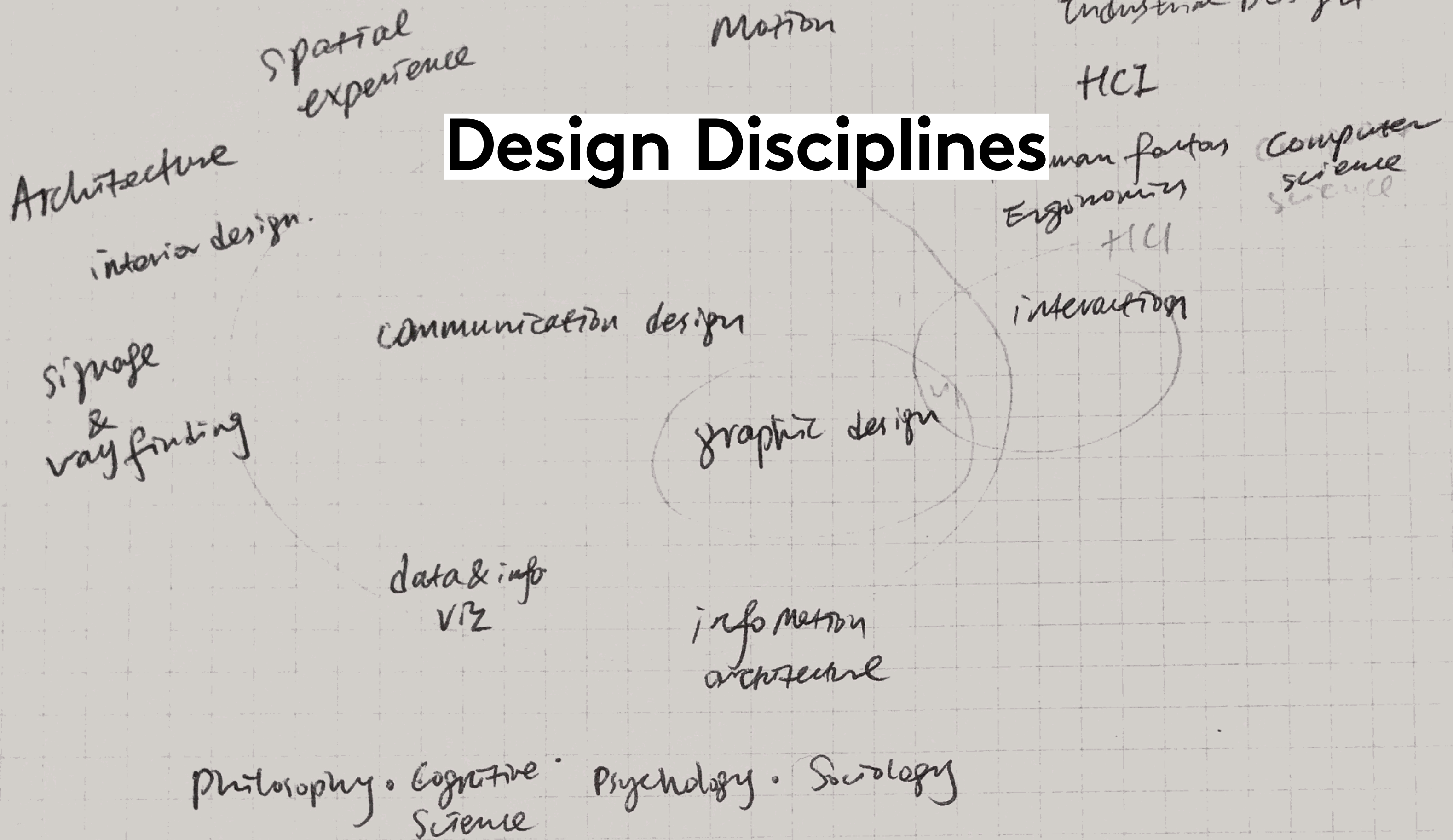

What is *design*

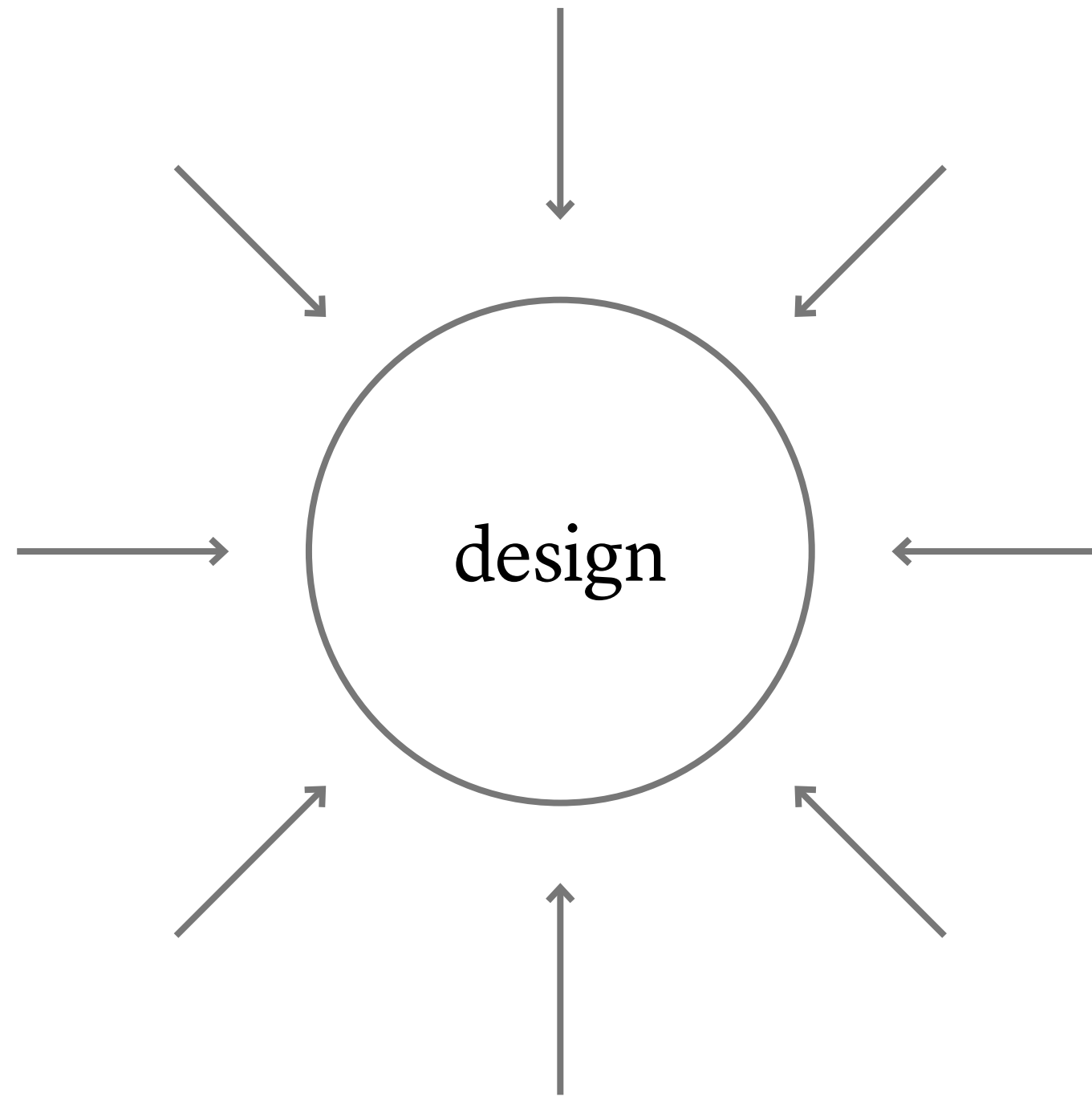

enter upon the examination of that school of Venetian architecture which forms an intermediate step between the Byzantine and Gothic forms; but which I find may be conveniently considered in its connexion with the latter style. ¶ In order that we may discern the tendency of each step of this change, it will be wise in the outset to endeavour to form some general idea of its final result. We know already what the Byzantine architecture is from which the transit was made, but we ought to know something of the Gothic architecture into which it is to be made. ¶ I shall endeavour therefore to give the reader in this chapter an idea, at once broad and definite, of the true nature of Gothic architecture, properly so called; not of that of Venice only, but of universal Gothic: for it will be one of the most interesting parts of our subsequent inquiry, to find out how far Venetian architecture reached the universal

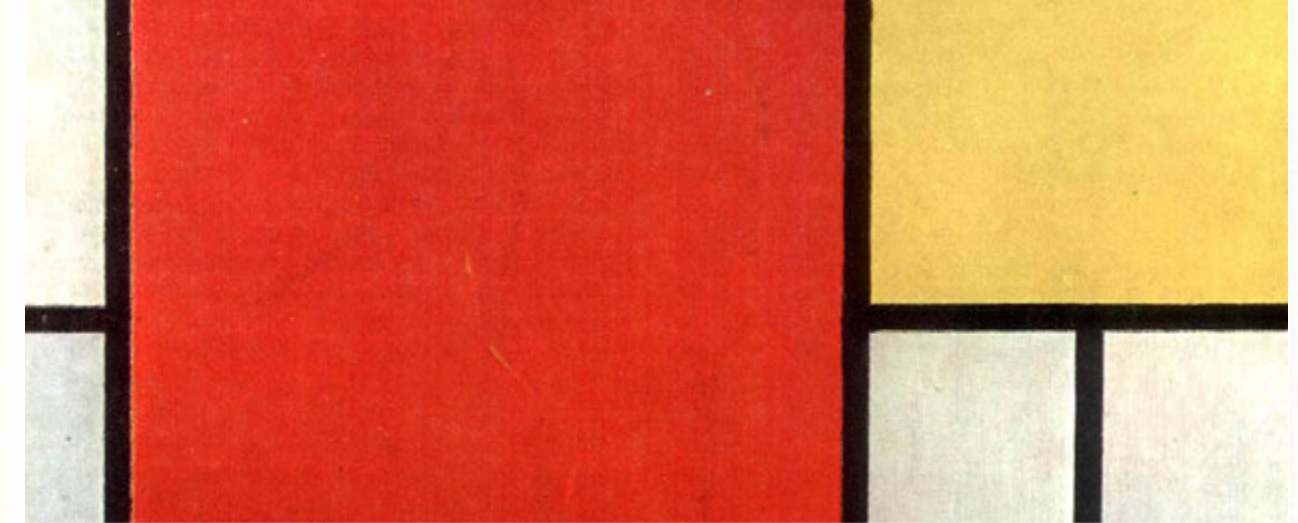

# New Graphic Design Graphisme actuel

Internationale Zeitschrift für Grafik und verwandte Gebiete  
Text in three languages  
Deutsch, englisch, französisch

International Review of Graphic Design and related subjects  
Issued in German, English and French

Revue internationale du graphisme et des domaines voisins  
Publiée en langues allemande, anglaise et française

# Art and design movements

Arts and Crafts

Art Nouveau

Art Deco and De Stijl

Bauhaus

International Typography Style

Postmodernism

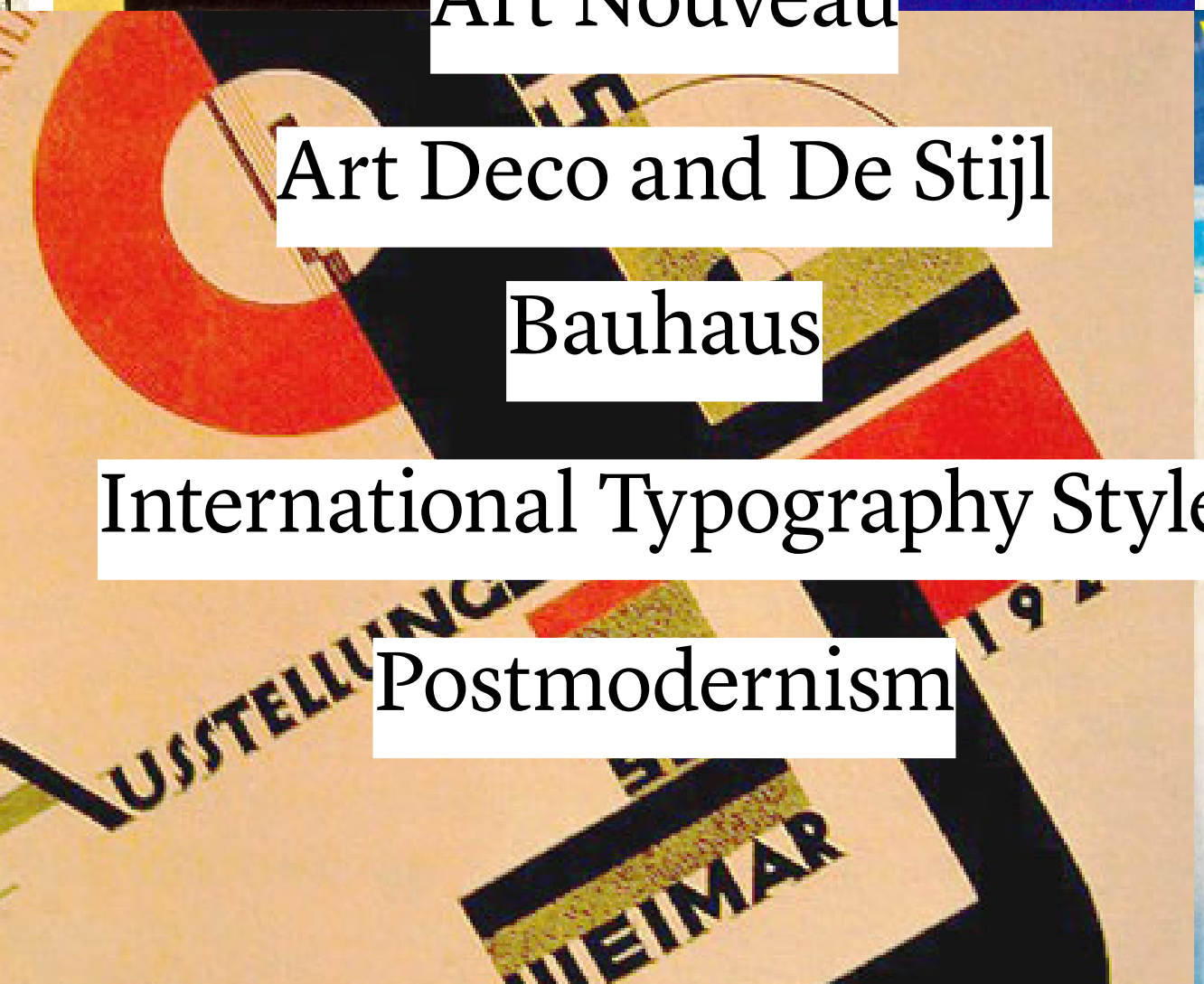

Issue for July 1963  
Contents  
Swiss Posters of the past four years  
A Sign System for Electromedical Instruments  
Progressive Elections Method  
Publicity for a London Firm of Furniture  
Pure Photo-Graphic Design  
Exhibition of Asbestos Pipes  
SWB Design Forum 1962  
Permanent Brown Pulpines  
as an Exhibition Site  
Book jackets of the Thirties  
A Poster who is his own Graphic Designer

Table des matières  
Affiches suisses des quatre années écoulées  
Un système de signes pour appareils électromédicaux  
Propagande électorale d'avant-garde  
Publicité pour une maison d'ameublement londonienne  
Photographie pure  
L'imposition des tubes de ciment d'amiante  
Forum 1962 de la forme ASAI  
Pulpines brunes permanentes sur l'agencement d'une foire  
Couvertures de protection des années trente  
Un peintre-graphiste

Single number Fr. 15.-



## What is *design*

*... culture was broken into two branches that were alienated from each other-the scientific, quantifiable “hard” and the aesthetic, qualitative “soft.” The word “design” leaped into the breach and provided a bridge.*

Vilém Flusser, *On the Word Design: An Etymological Essay*, *Design Issues*, Volume 11, No. 3, 1995

What is *design*

Need-driven tangible products

Systematic thinking

Service based model

# Modalities of Design

Communication Design  
*delivering messages*

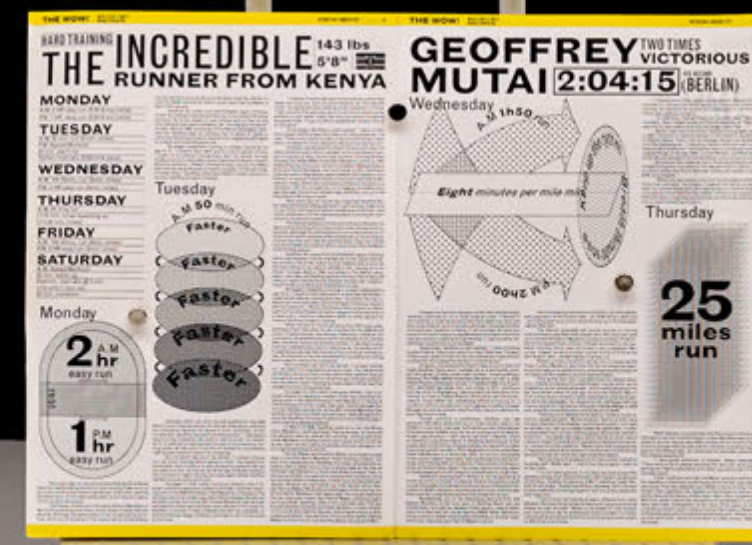
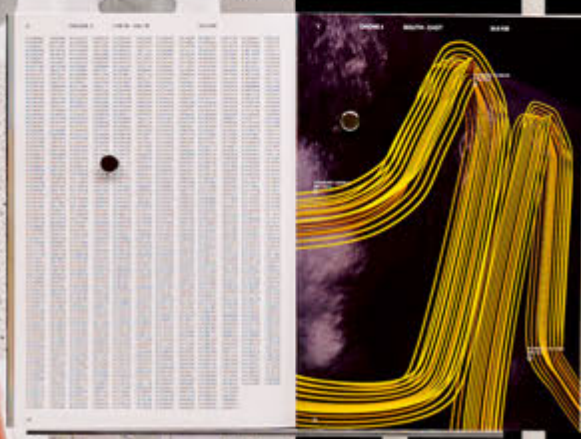



WUNSCHGRÖSSE IHRES HAUSHALTS

# Modalities of Design

WOHNFLÄCHE  
BIS 35 m<sup>2</sup>

WOHNFLÄCHE  
35-80 m<sup>2</sup>

WOHNFLÄCHE  
80-120 m<sup>2</sup>

WOHNFLÄCHE  
MEHR ALS 120 m<sup>2</sup>

Interface/Interaction Design

*user experience; behavior of products, people and systems*

VIELFÄLTIGE NUTZUNG DES  
ÖFFENTLICHEN RAUMS

- Strassen als Begegnungsräume für Anwohner und Spielort für Kinder
- Gestaltung des öffentlichen Raums gemäss den Bedürfnissen der Menschen

# Modalities of Design

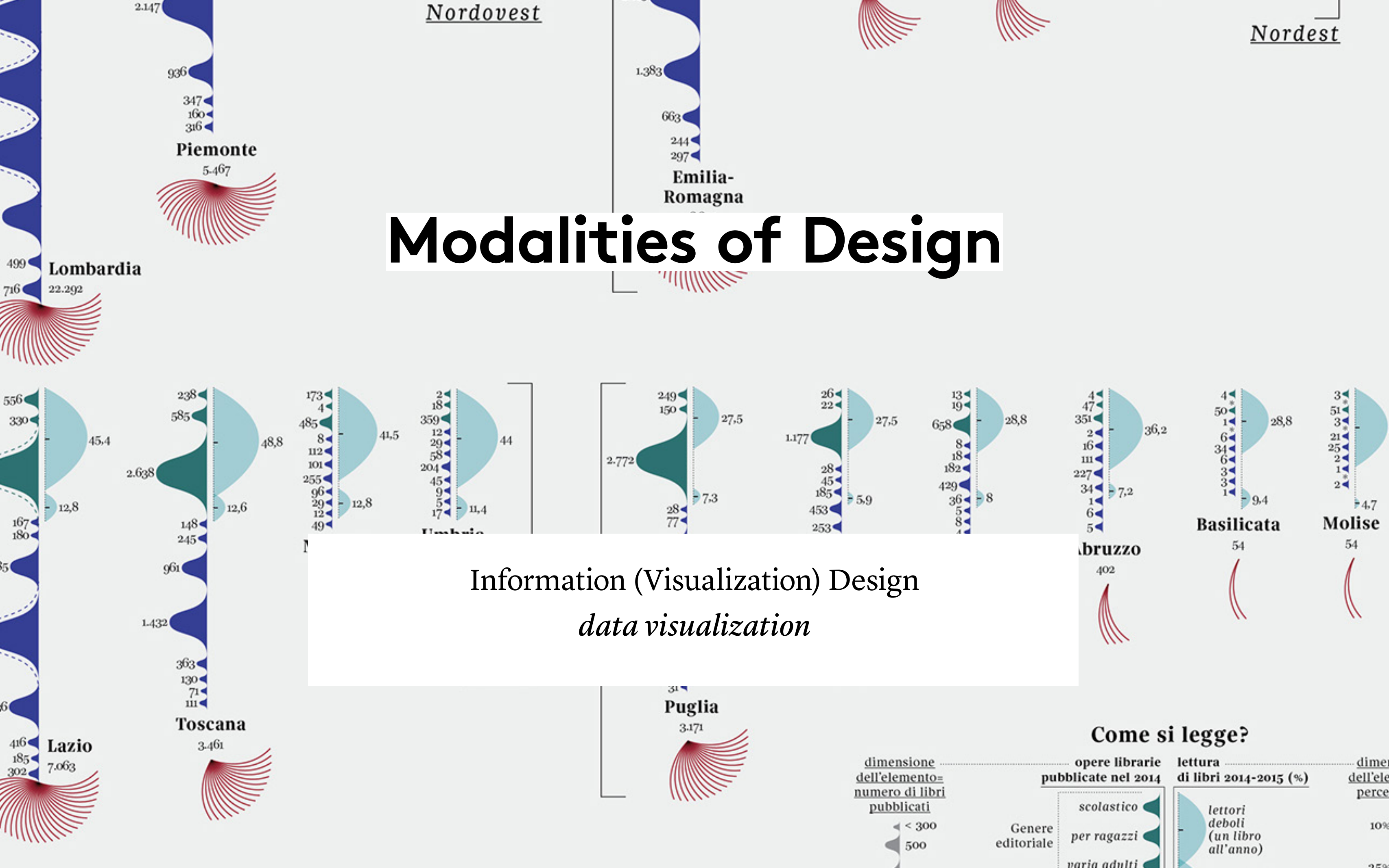

Nordovest

Nordest

**Piemonte**

5-467

**Emilia-Romagna**

**Lombardia**

22.292

45,4

48,8

41,5

44

27,5

27,5

28,8

36,2

28,8

4,7

**Toscana**

3-461

**Puglia**

3-171

**Lazio**

7.063

**abruzzo**

402

**Basilicata**

54

**Molise**

54

2.147  
936  
347  
160  
316

1.383  
663  
244  
297

499  
716

556  
330

238  
585

173  
4  
485

2  
18  
359

249  
150

26  
22

13  
19

4  
47  
2

4  
50  
1

3  
51  
3

167  
180

148  
245

8  
112  
101  
255  
96  
29  
12  
49

12  
29  
58  
204  
45  
9  
5  
17

28  
77

1.177  
28  
45  
185  
453  
253

8  
182  
429  
36  
5  
8  
4

351  
16  
111  
227  
34  
1  
6  
5

6  
34  
6  
3  
3  
1

21  
25  
2  
1  
2

35

961

12,8

11,4

7,3

5,9

8

7,2

9,4

4,7

6

1.432

12,8

11,4

7,3

5,9

8

7,2

9,4

4,7

416  
185  
302

363  
130  
71  
111

12,8

11,4

7,3

5,9

8

7,2

9,4

4,7



What is *design*

# Modalities of Design

Dunne & Raby  
Metahaven

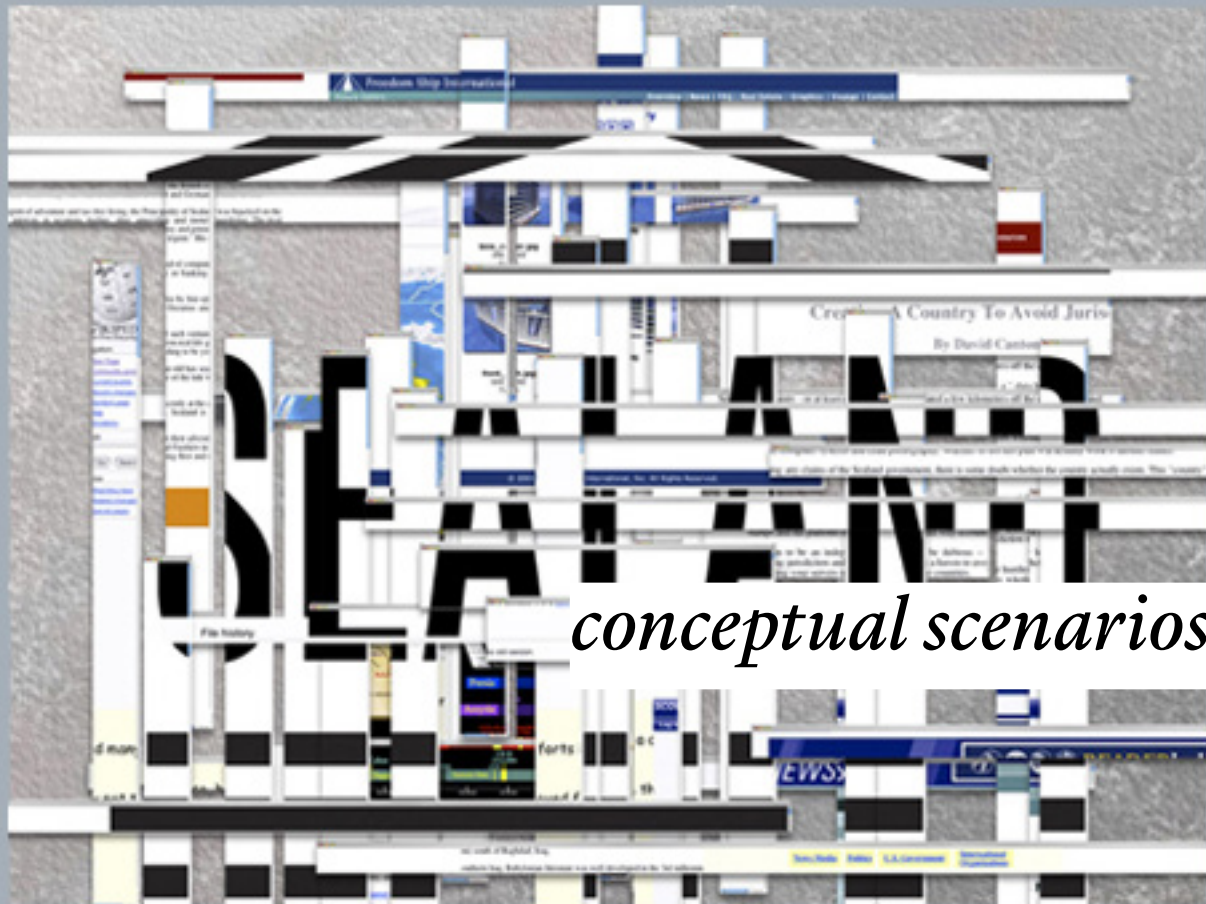

Critical Design

*conceptual scenarios; hypothetical objects; social-political-cultural commentary, speculative*

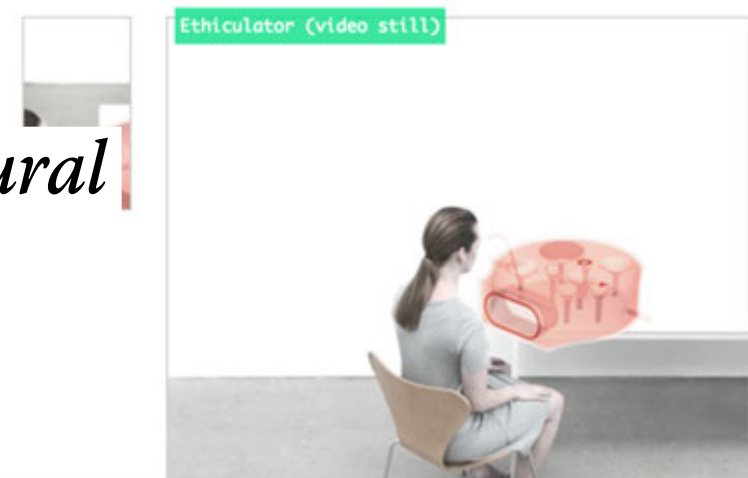

What is *design*

# Modalities of Design

Communication Design

*delivering messages*

Interface/Interaction Design

*user experience; behavior of products, people and systems*

Information (Visualization) Design

*data visualization*

Critical Design

*conceptual scenarios; hypothetical objects; social-political-cultural  
commentary, speculative*

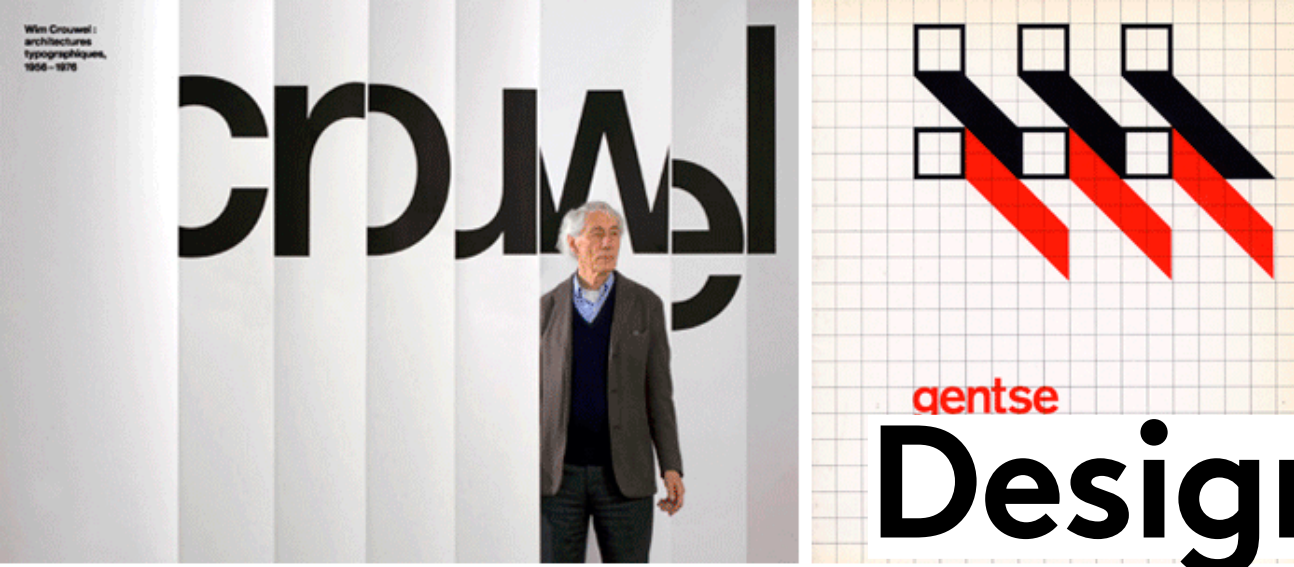

What is *design*

# Designer as Author vs. Transparency of Information



*The Crystal Goblet, or Printing Should Be Invisible by Beatrice Warde (1900 - 1969)*

*Wim Crouwel and Jan Van Toorn  
rational approach vs. personal approach*



# Visual Language: Language of forms

A system of communication using visual elements

*designs are able to convey complex information that are usually thought to be non-visible by using visual elements*



Visual Language

# Visual Language: Language of forms

Its structural units include line, shape, color, form, motion, texture, pattern, direction, orientation, scale, angle, space and proportion.

# What constitute a language

signs [morphemes, words, phrases, and texts] +  
meanings + code > semiotics

grammar [rules] > semantics > morphology [homonymy, synonymy, antonymy, hypernymy, hyponymy, meronymy, holonymy]

subjects, predicators > syntax



# Visual Language in Information Graphics

Two aspects:

1. A highly formal set of **visual elements** with rules for their use
2. A **verbal description** of this system and the way it works

Visual Language

PERSON

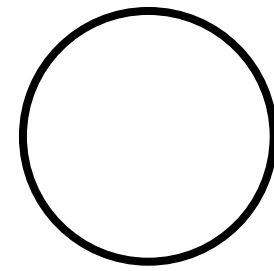

# Visual Language

**code**  
*visual language*

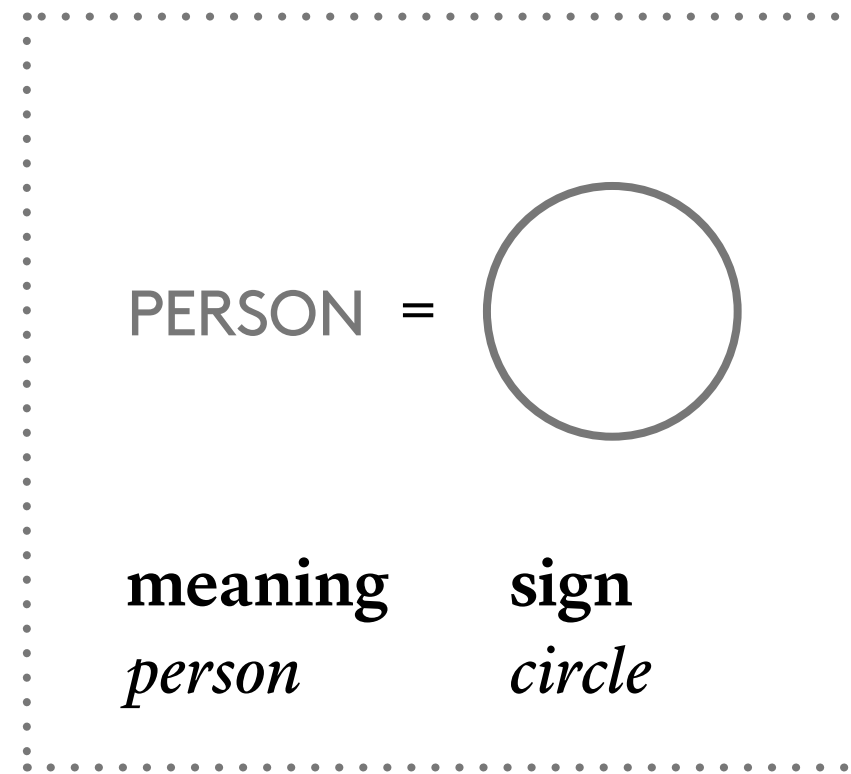

semiotics

Visual Language

**sign    signifier    signified**

**semiotics**

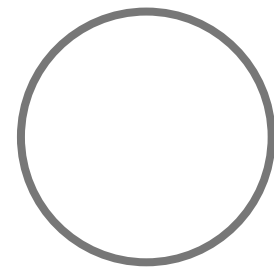

*:person*

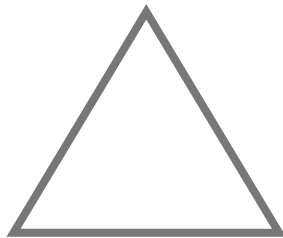

*:cat*

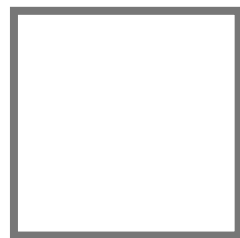

*:dog*

# Visual Language

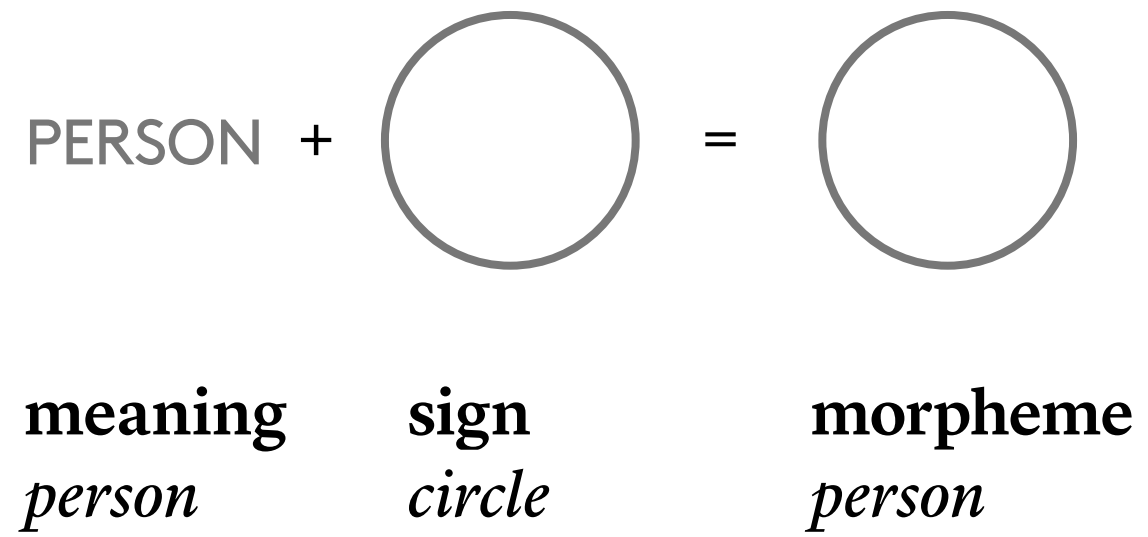

Visual Language

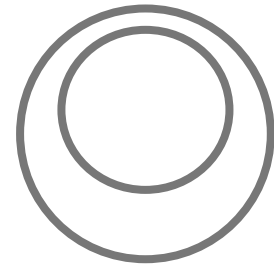

**morpheme**  
*family*

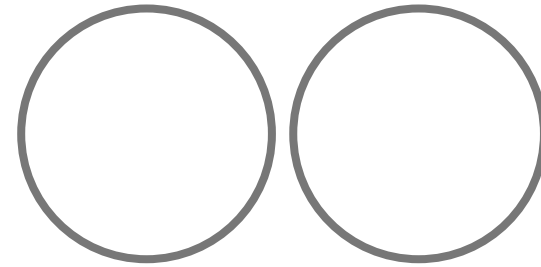

**morpheme**  
*couple*

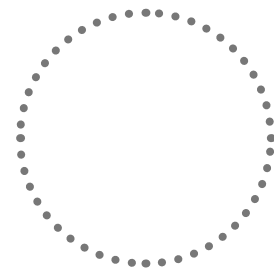

**morpheme**  
*weird person*

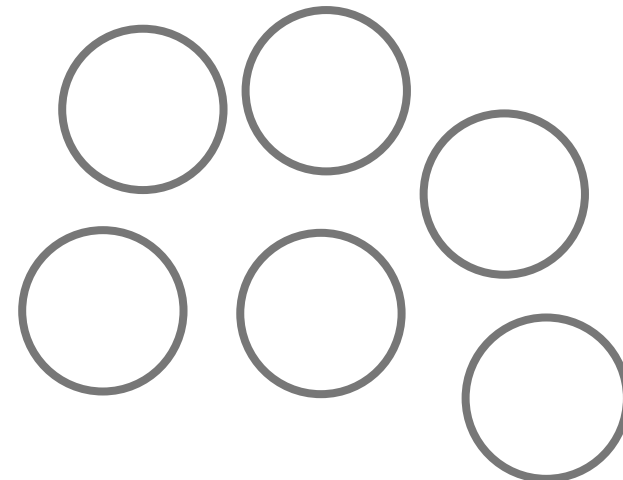

**morpheme**  
*crowd*

**Semantics**  
*the study of meaning*

**Morphology**  
*the study of morphemes*

# Visual Language

**subject**  
*person*      **predicator**  
*love*      **object**  
*person*

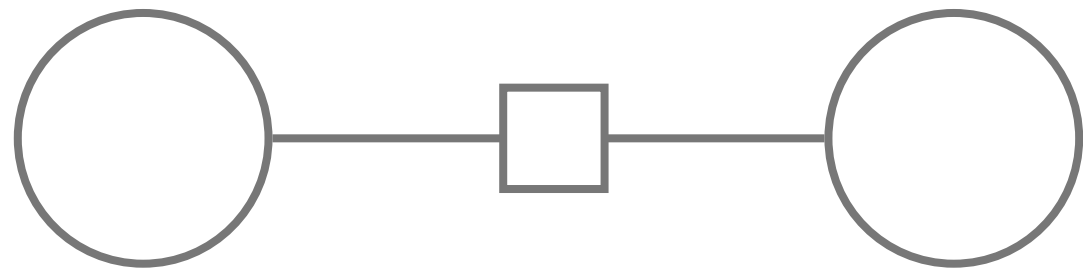

**morpheme**  
*person*      **morpheme**  
*love*      **morpheme**  
*person*

**Grammar**  
*the rules to combine*

# Visual Language

**subject**    **object**    **predicator**  
*person*    *person*    *love*

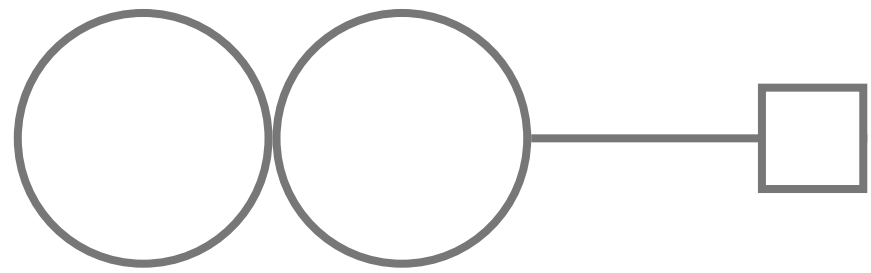

**Syntax**  
*the order*

**morpheme**    **morpheme**    **morpheme**  
*person*    *person*    *love*



# Visual Language

**predicator**

*love*

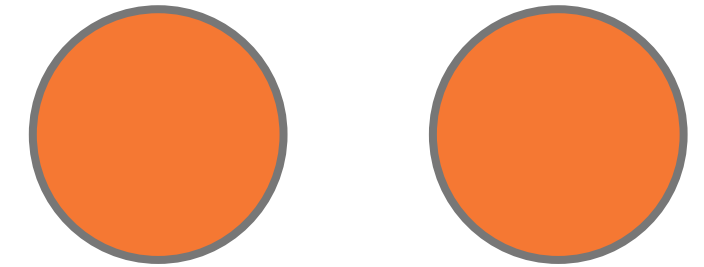
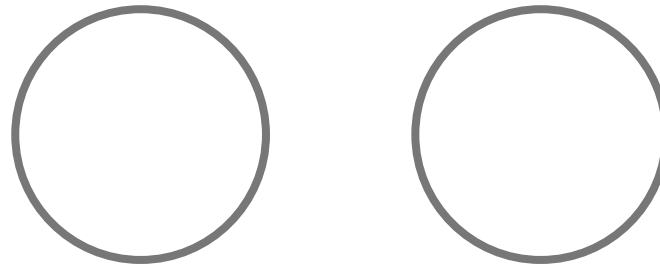
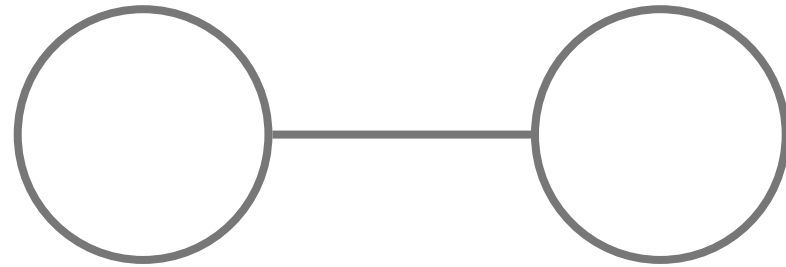

*loved*

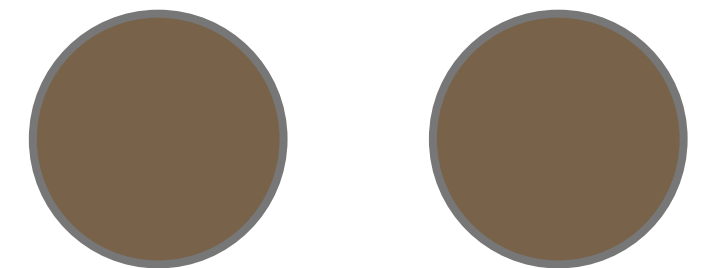

*love too much*

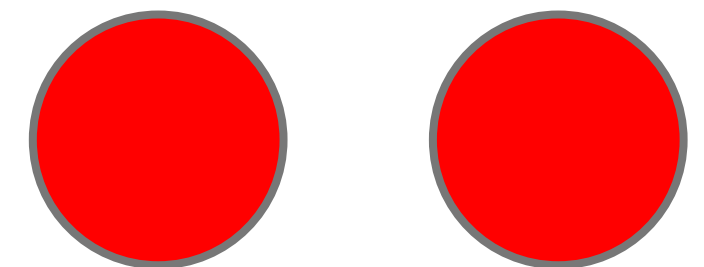
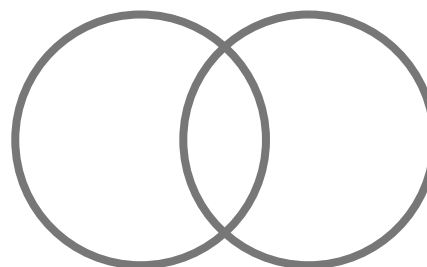

# Rhetoric and Semiotics



**icon**

*the sign resembled  
what it stands for*



**index**

*the sign associate with what  
it is a sign of*



**symbol**

*the sign is only arbitrarily  
or conventionally linked  
with its referent*

Visualization

# What is a medium

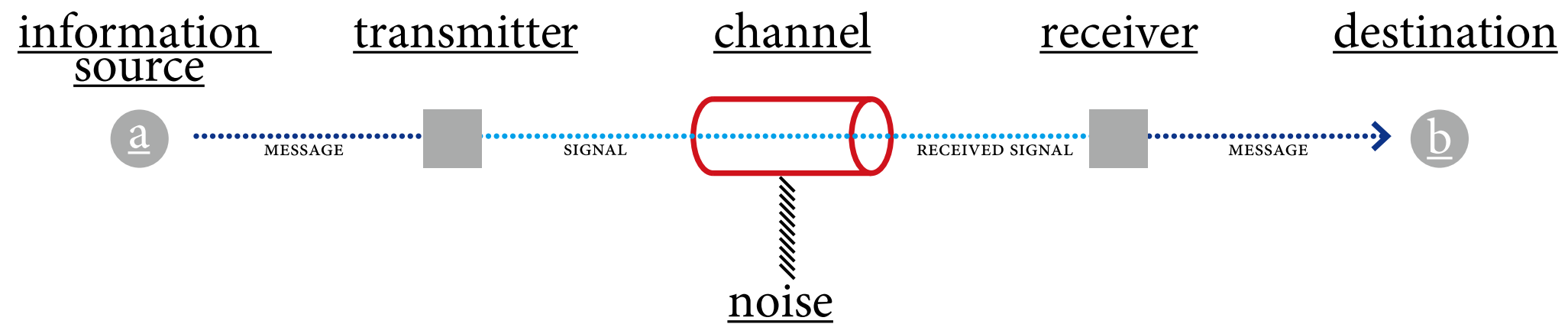

Shannon theory  
A Mathematical Theory of Communication

Visualization

# Visualization as Medium

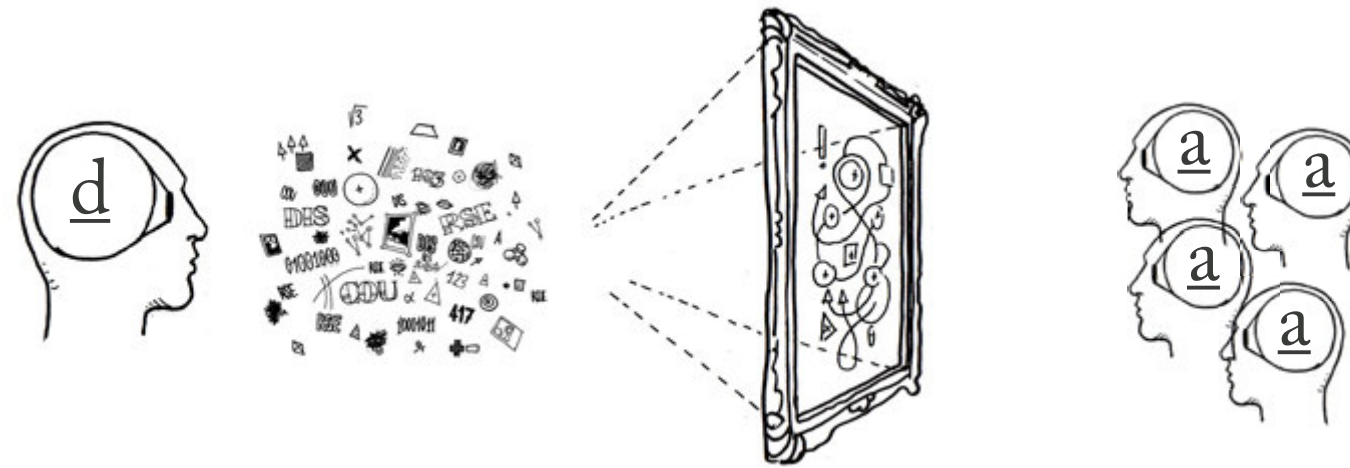

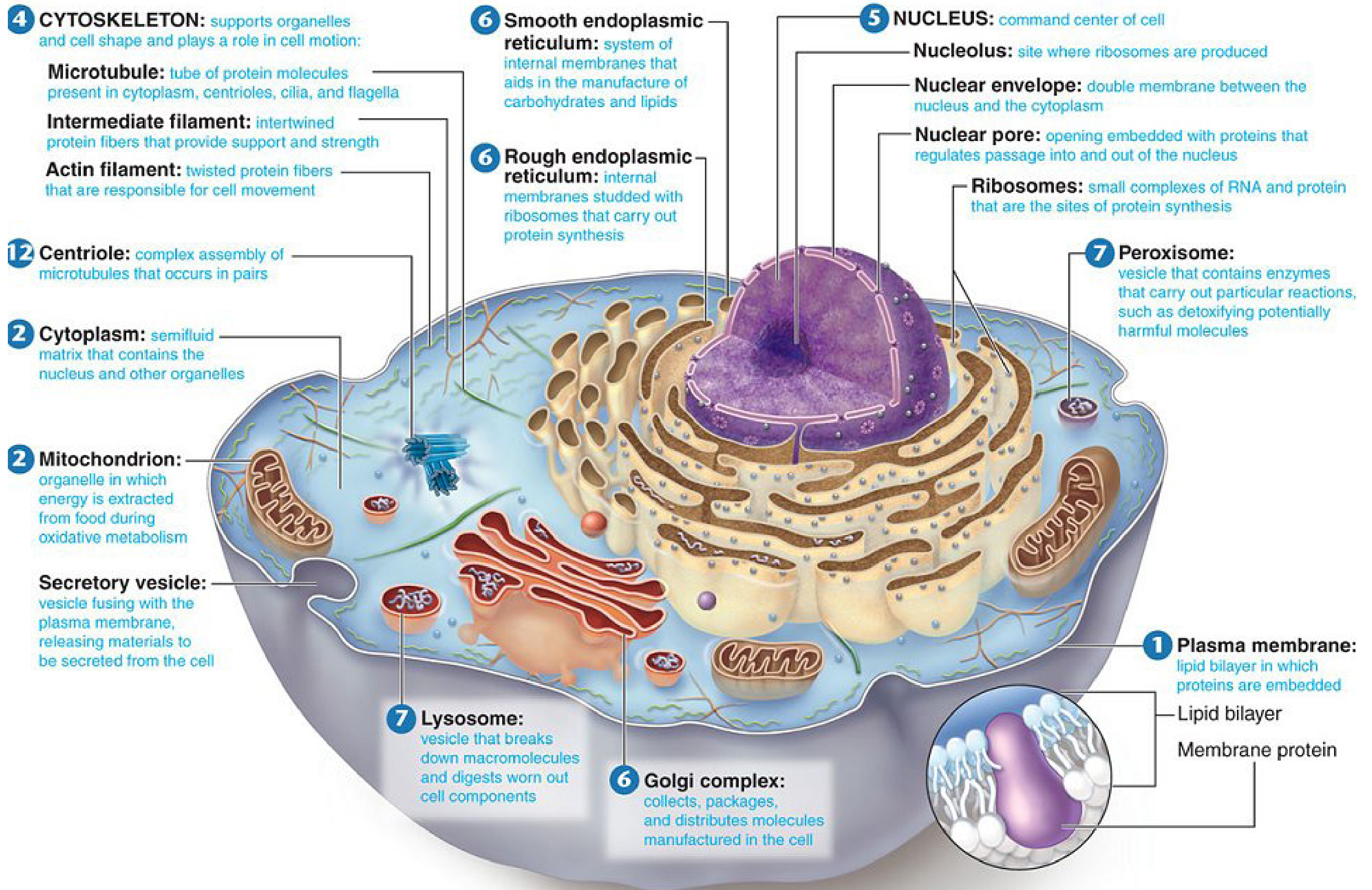

Visualization

# Visualization as Tool

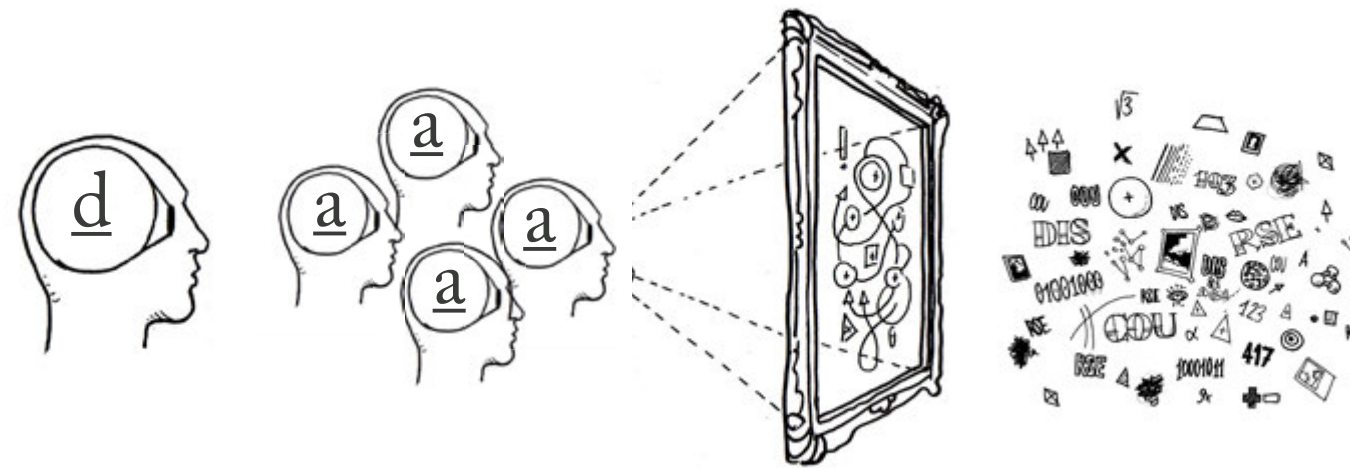

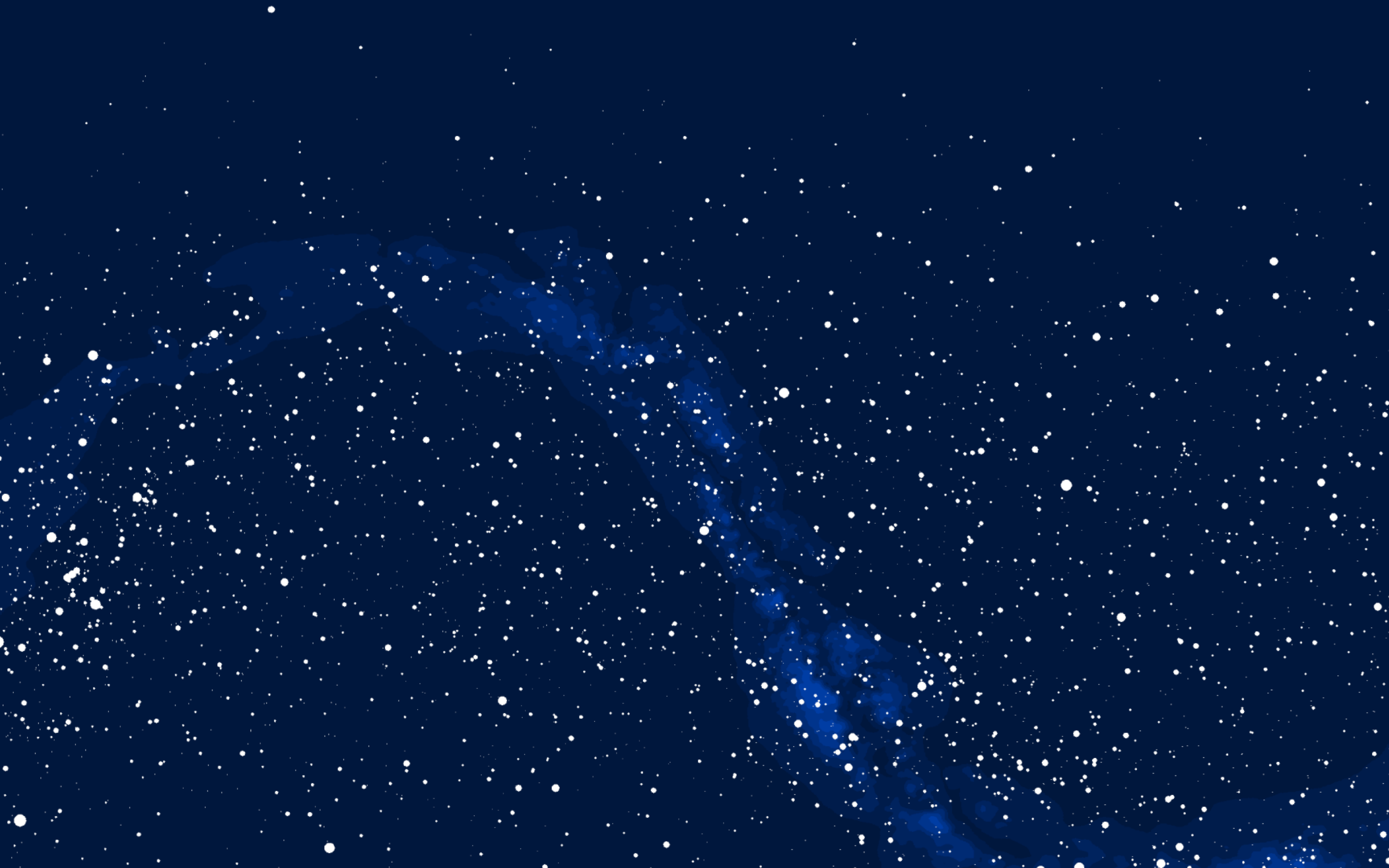



Camelopardalis

Cepheus

Ursa Minor

Cassiopeia

Draco

Perseus

Cygnus

Hercules

Ursa Major

Andromeda

Lacerta

Lyra

Boötes

Canes Venatici

Ursa

Triangulum

Andromeda

Lacerta

Cygnus

Lyra

Hercules

Ursa Major

Leo Minor

Taurus

Aries

Pisces

Pegasus

Vulpecula

Sagitta

Corona Borealis

Coma Berenices

Leo

Orion

Delphinus

Equuleus

Serpens

Ophiuchus

Serpens

Virgo

Sextans

Procyon

Cetus

Aquarius

Capricornus

Aquila

Scutum

Ophiuchus

Libra

Corvus

Crater

Eridanus

Lepus

Columba

Fornax

Sculptor

Piscis Austrinus

Sagittarius

Scorpius

Corona Austrina

Ara

Norma

Lupus

Circinus

Centaurus

Antlia

Caelum

Grus

Microscopium

Telescopium

Pictor

Horologium

Phoenix

Indus

Norma

Lupus

Circinus

Ve



Visualization

# Medium vs. Tool

*Representative vs. Generative*

# BILLY

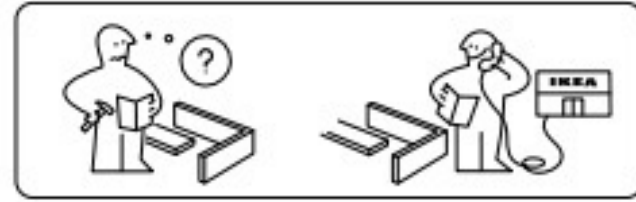
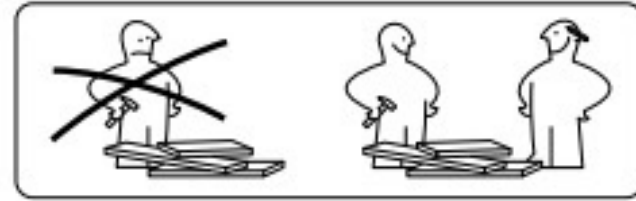
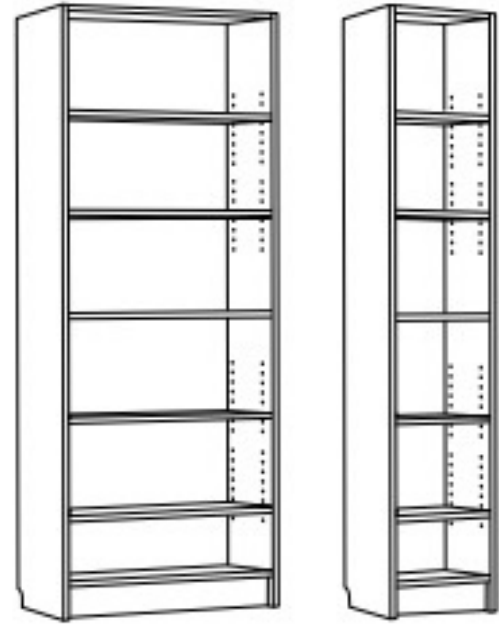

2

AL/100/14

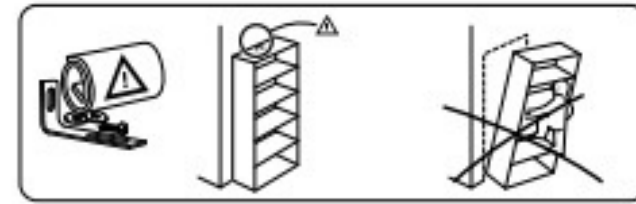

3

AL/100/14

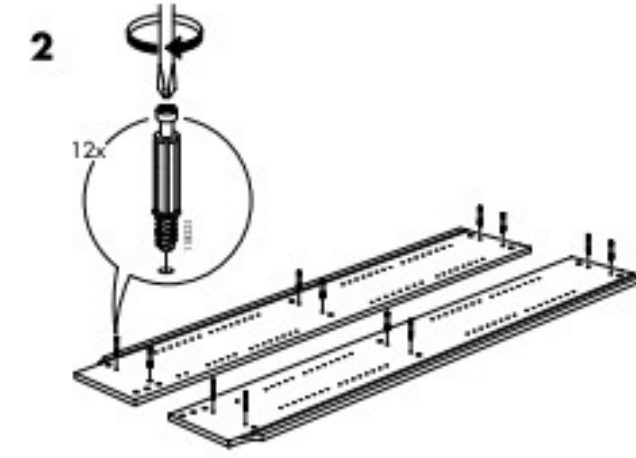
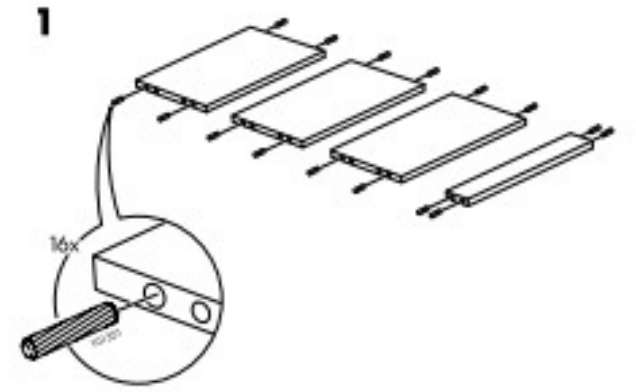

4

AL/100/14

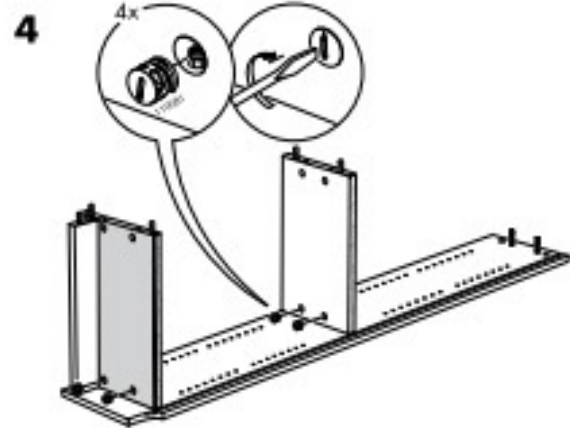
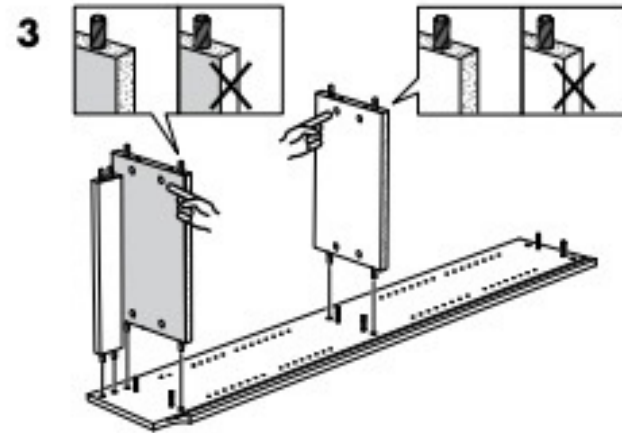

5

AL/100/14

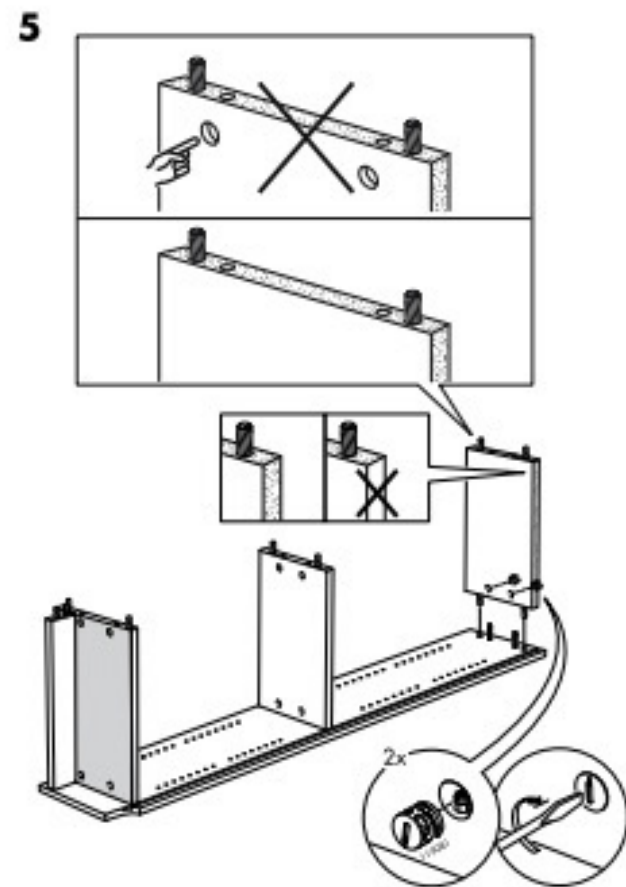

6

AL/100/14

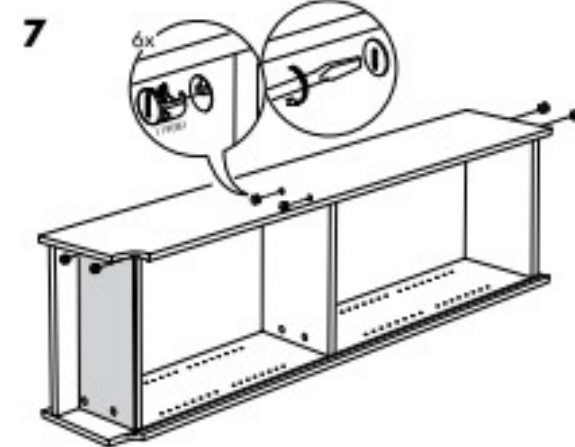
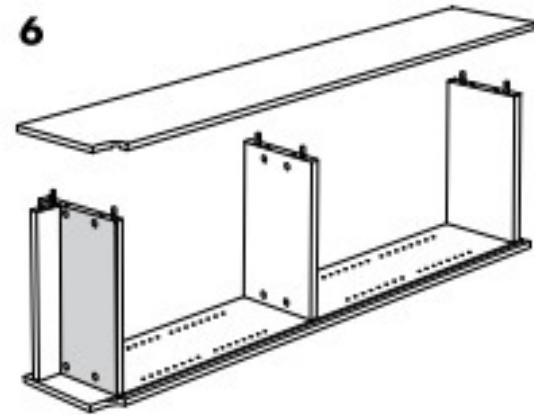

7

AL/100/14

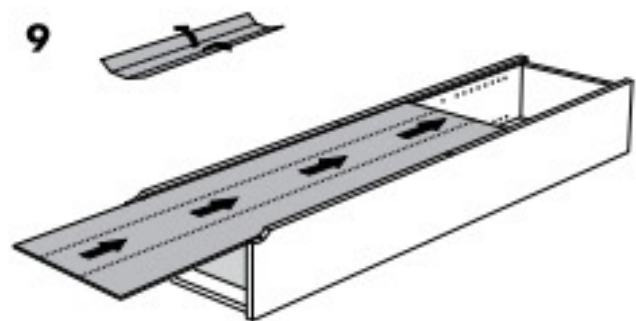
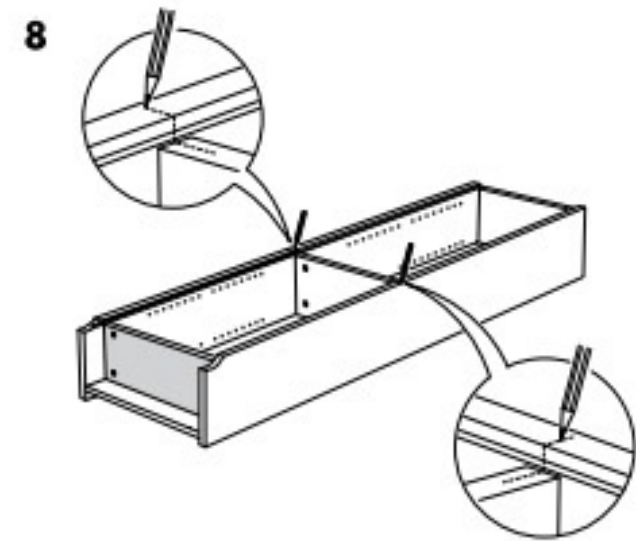

8

AL/100/14



Visualization

DIKW pyramid  
Ackoff (1989)

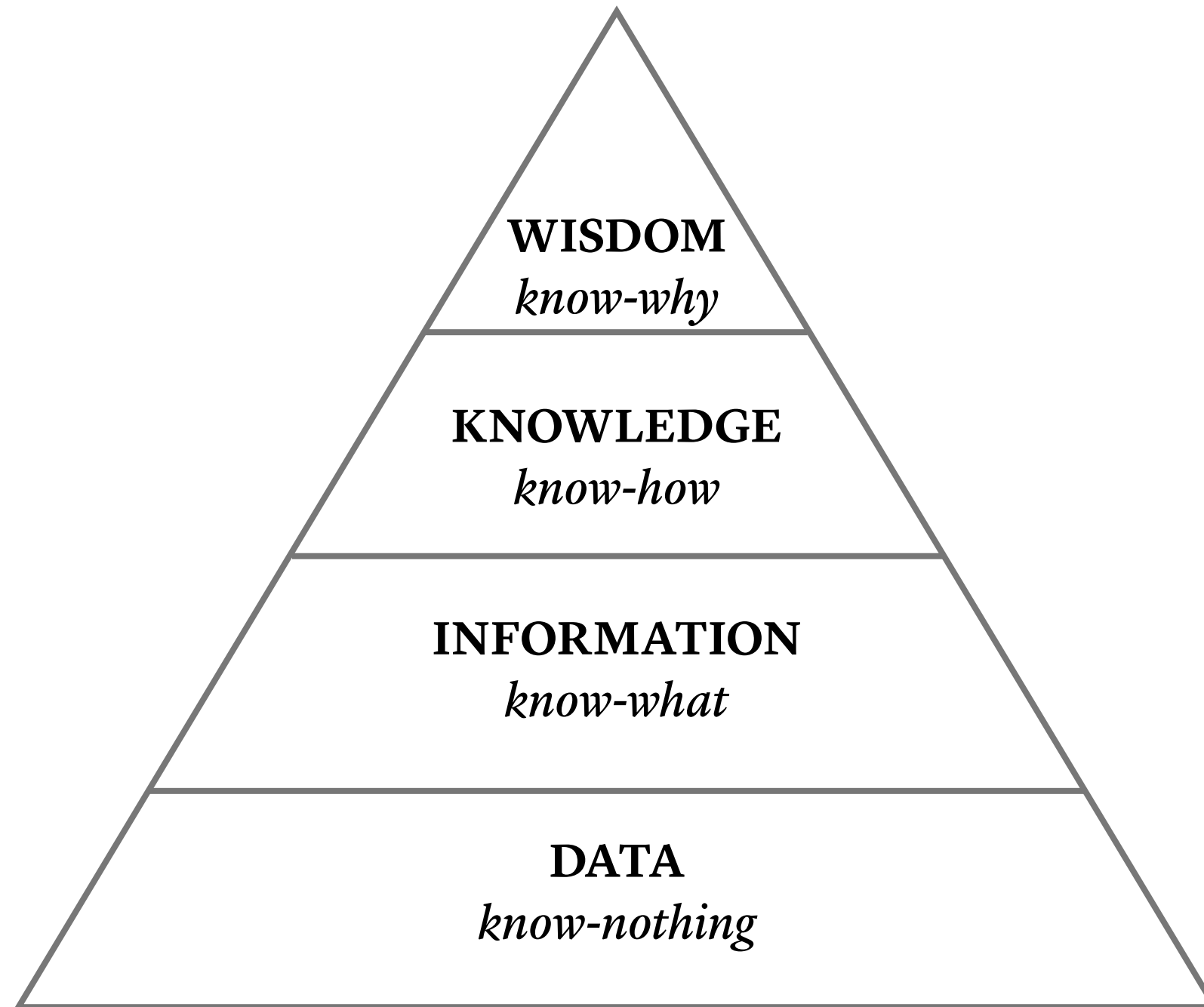

DATA

500 kg



Flight Patterns by Aaron Koblin

A nighttime photograph of the Shanghai skyline, featuring the Oriental Pearl Tower and the Shanghai Tower. The city lights are visible against a dark sky with some clouds. The text is overlaid on the image.

## INFORMATION

Shanghai is larger than New York City



**Caffé Latte**

[caf-ay lah-tey]



KNOWLEDGE

**Flat White**



**Caffé Breve**

[caf-ay brev-ay]



**Cappuccino**

[kap-oo-chee-noh]



**Caffé Mocha**

[caf-ay moh-kuh]



**Americano**

[uh-mer-i-kan-oh]



Visualization

DIKW pyramid  
Ackoff (1989)

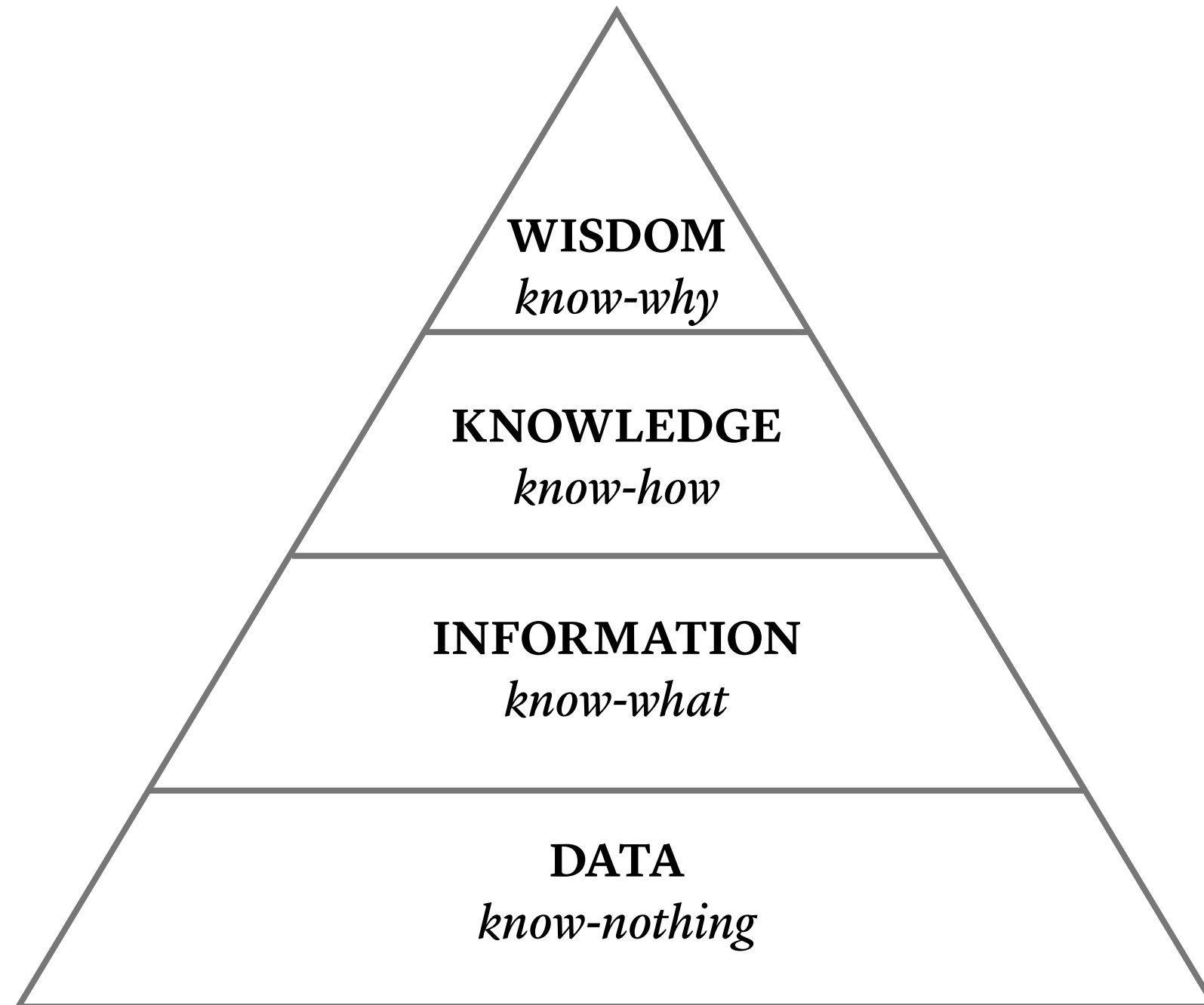

PEDIGREE OF MAN.

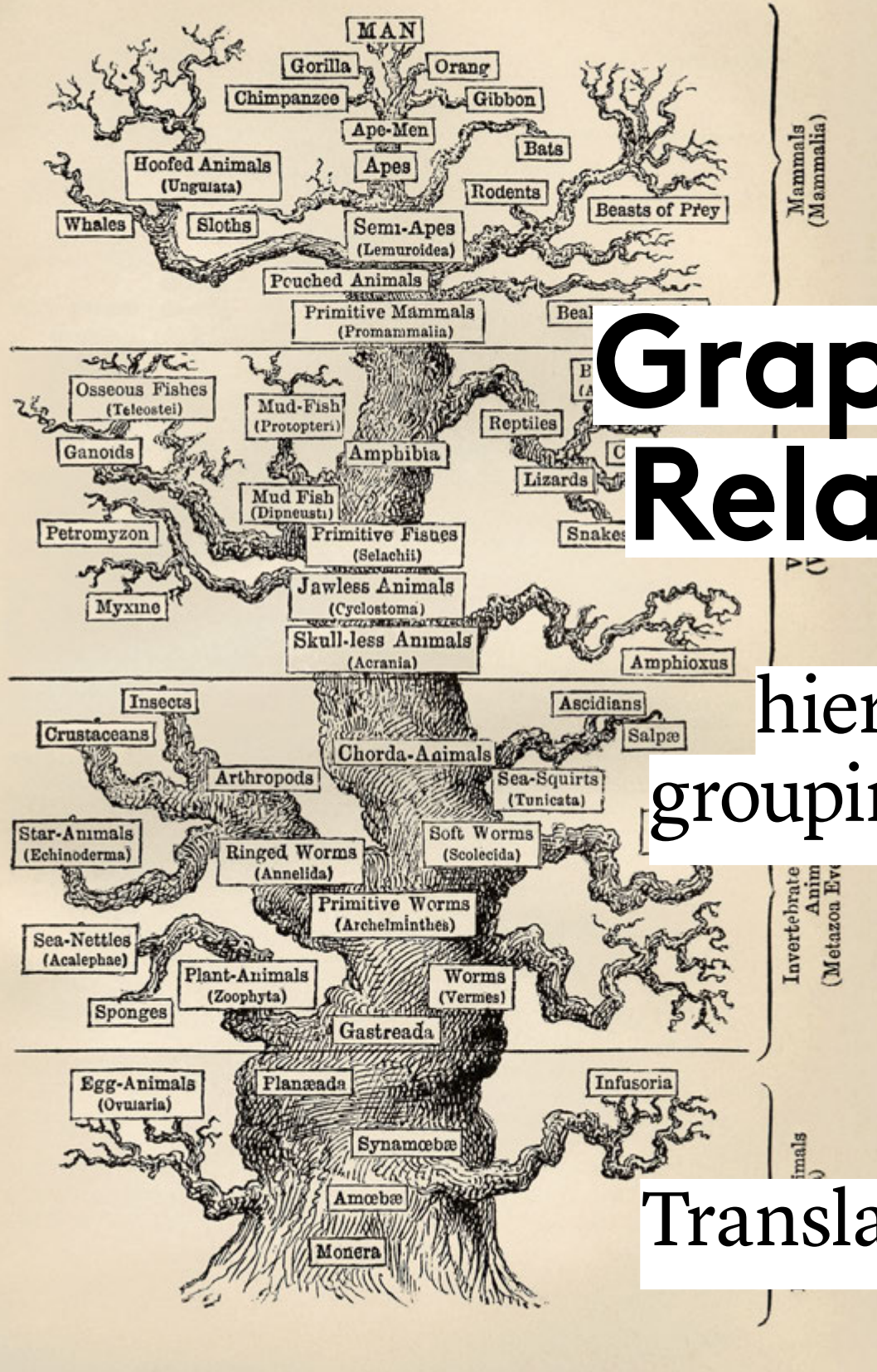

Visualization

# Graphical elements and Relational information

hierarchy, juxtaposition, proximity  
grouping, separation by lines, alignment,  
connectivity, orientation

Translation from statistic parameters into graphical elements

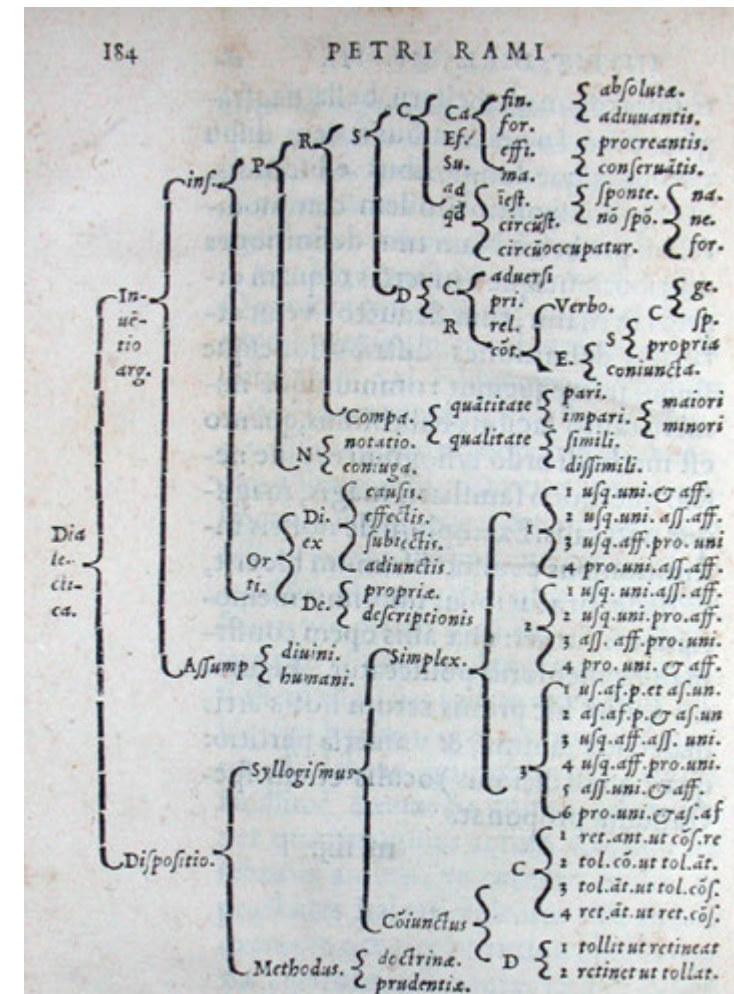

Visualization

**Conventional quantitative diagram  
vs.  
Humanistic/constructive approach**

*Qualitative display of graphical information  
Recognition of the interpretative nature of knowledge*

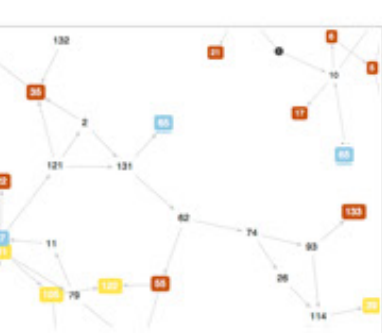

**Force.js**  
A library of force-directed layout algorithms plus abstractions for graph operations and refresh handling.

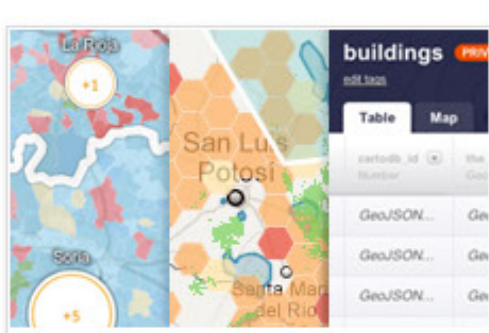

**CartoDB**  
A web service for mapping, analyzing and building applications with data.

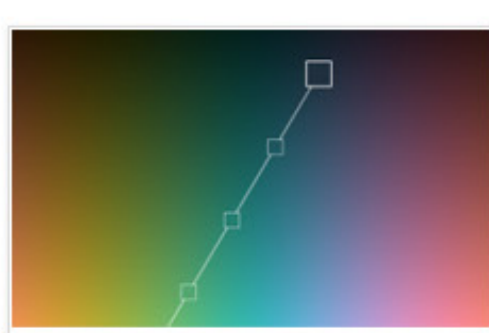

**Chroma.js**  
Interactive color space explorer that allows to preview a set of linear interpolated equidistant colors.

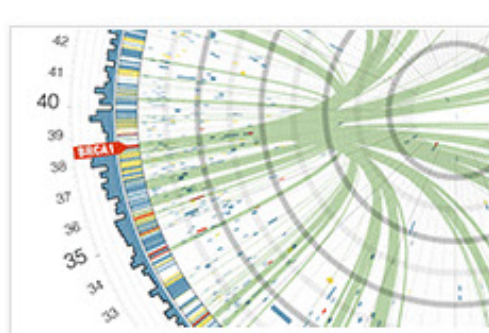

**Circos**  
A software package for visualizing data in a circular layout.

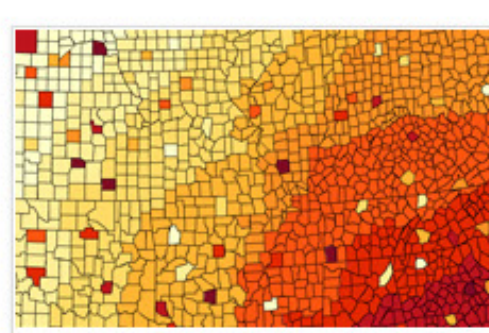

**ColorBrewer**  
A web tool for selecting colors for maps.

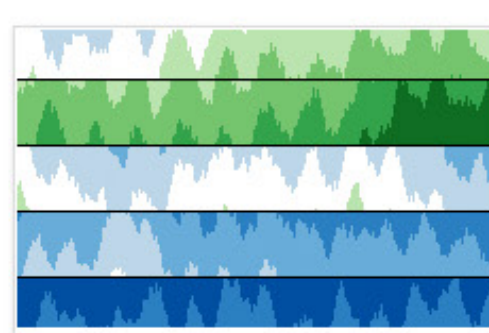

**Cubism.js**  
A library for creating interactive time series and horizon graphs based on D3.js



**D3.js**  
An small, flexible and efficient library to create and manipulate interactive documents based on data.

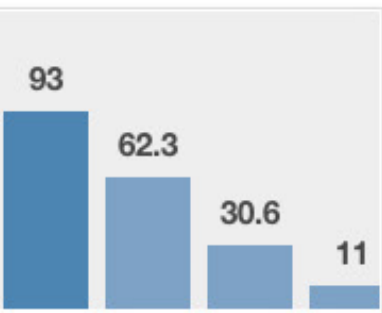

**Score.js**  
A data-driven visualization framework based on Data.js and Score.js



**Data.js**  
A data representation framework providing a uniform interface to domain data.



**Transform Script**  
Split data repeatedly on newline into rows

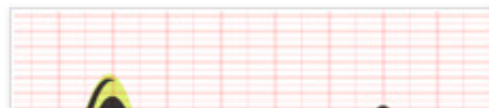

# Concealed bias Reductive

*No data exist pre-exist their parameterization*



**Flare**  
A set of software tools for creating rich interactive data visualizations in ActionScript.

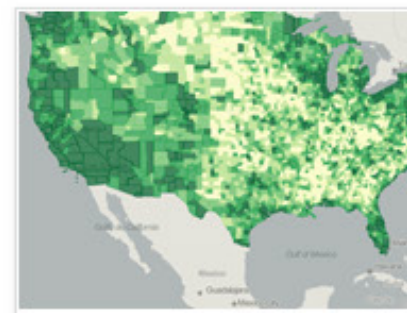

**GeoCommons**  
A public community and set of tools to access, visualize and analyze data with compelling map visualizations

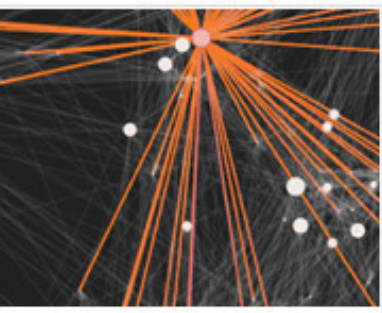

**Network.js**  
A library for visualization and exploration of networks with dynamic hierarchical graphs.

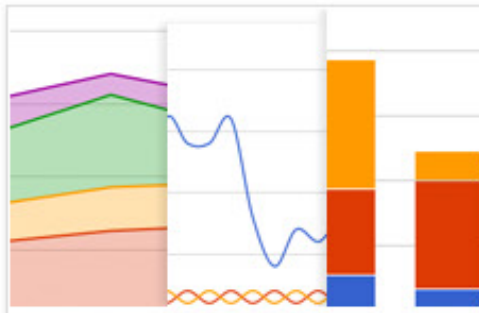

**Google Chart Tools**  
A collection of simple to use, customizable and free to use interactive charts and data tools.

A web application that makes it easy to host, manage, collaborate on, visualize, and publish data tables.

A tool for working with data, cleaning it up, reformatting it or extending it with web services.

A visual programming language aimed to gather, process and visualize information.

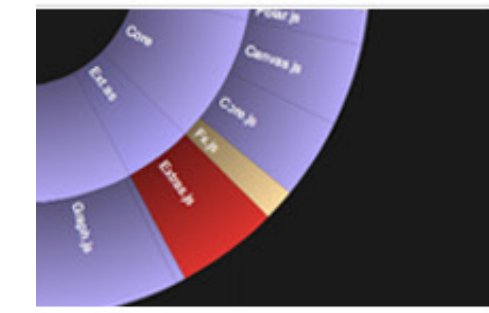

**JavaScript InfoVis Toolkit**  
A Javascript library that provides tools for creating interactive data visualizations for the web.



**Kartograph**  
A simple and lightweight framework for creating beautiful, interactive vector maps.

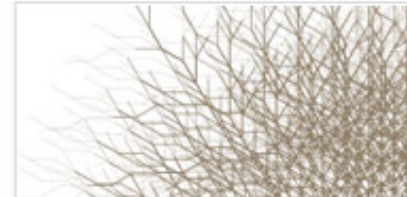
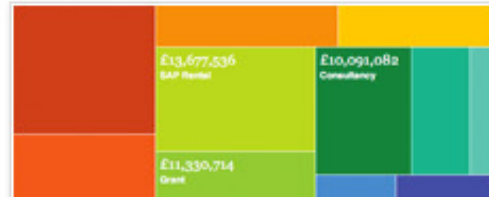
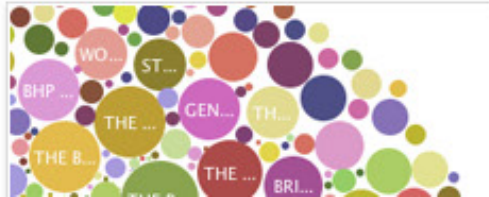

la vita dei cittadini europei per  
 caratterizzata da 11 categorie, e per  
 da sinistra a destra tre fasce di  
 dia e alta. A destra di ogni fascia è  
 disfasione della categoria.  
 tà e Sicurezza non prevedono un  
 istrazione non prevede le tre fasce  
 ale. La ricerca è relativa oltre che  
 ia e Svizzera. FONTE: EUROSTAT

- CATEGORIE
1. SODDISFAZIONE GENERALE
  2. CONDIZIONI MATERIALI
  3. SODDISFAZIONE ABITATIVA
  4. OCCUPAZIONE
  5. USO DEL TEMPO
  6. ISTRUZIONE
  7. SANITÀ
  8. RELAZIONI SOCIALI
  9. SICUREZZA
  10. AMBIENTE
  11. AMMINISTRAZIONE

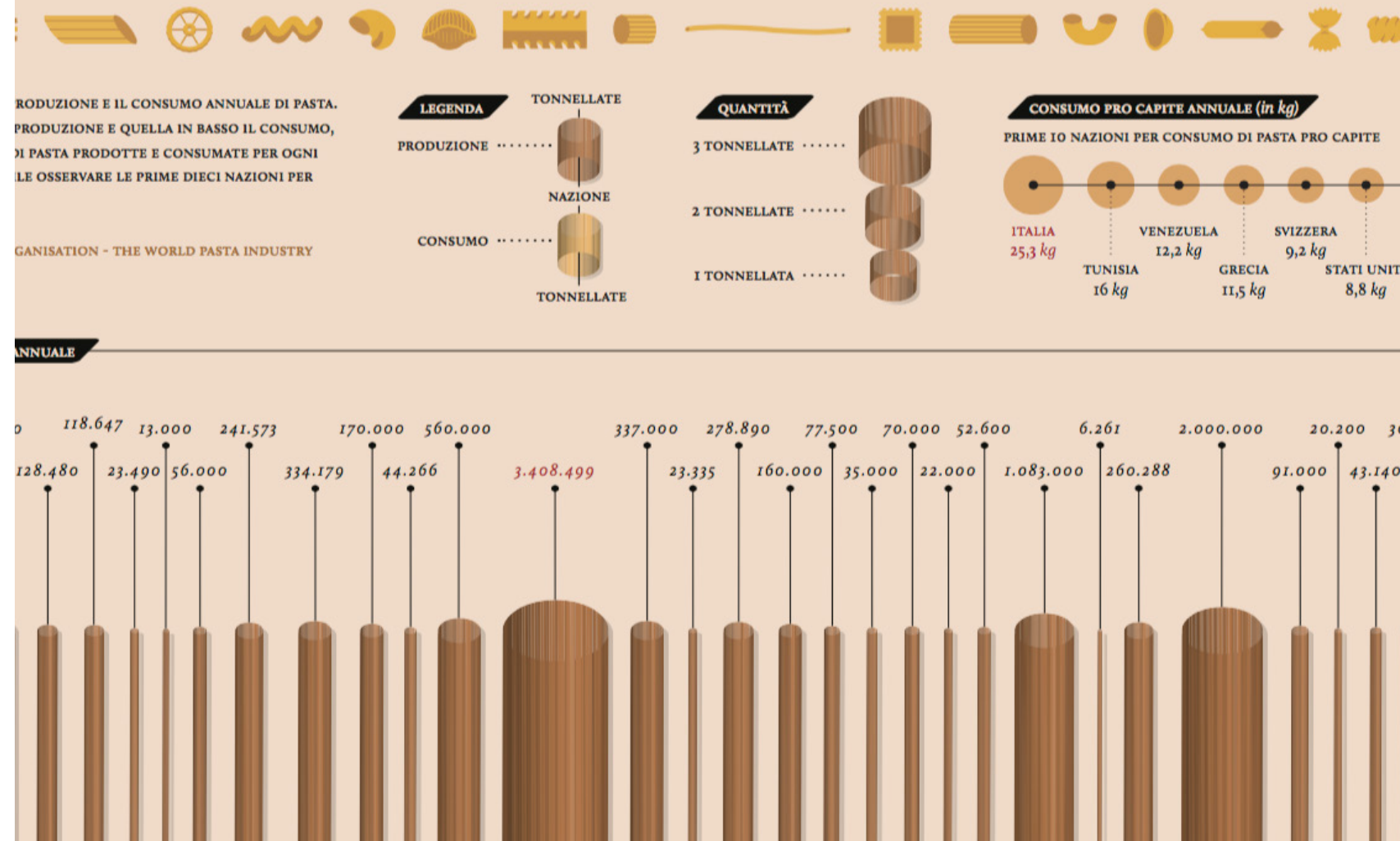
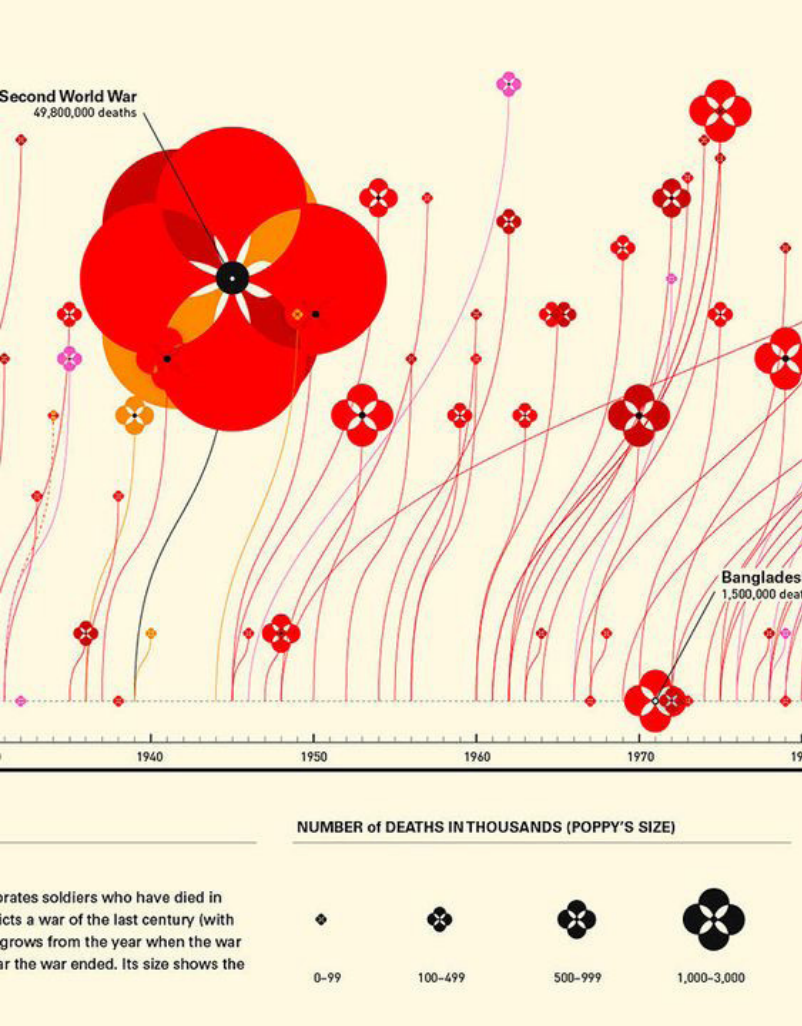
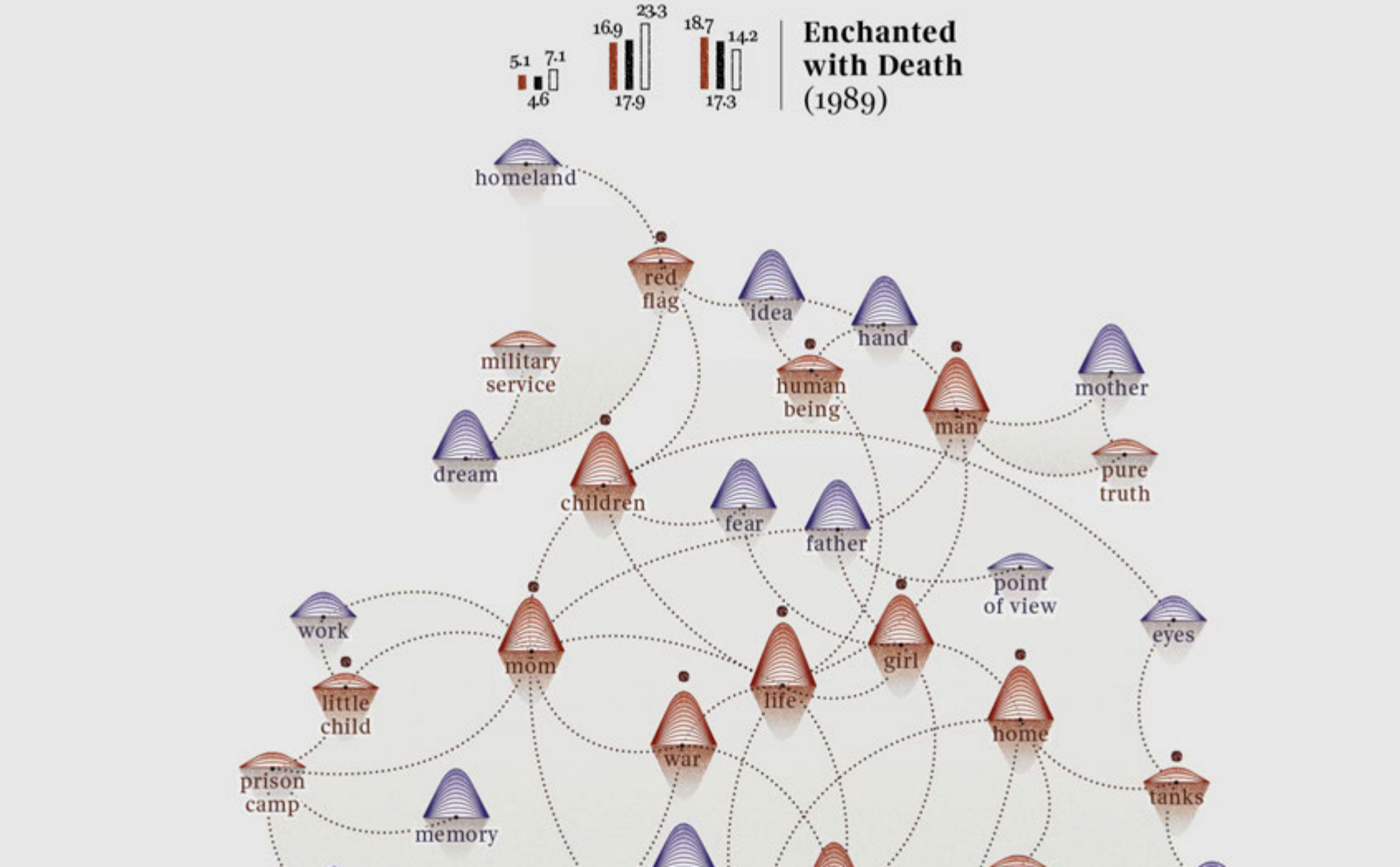
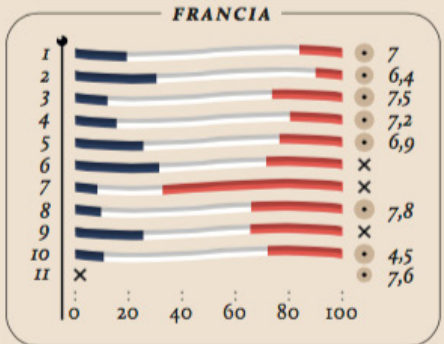
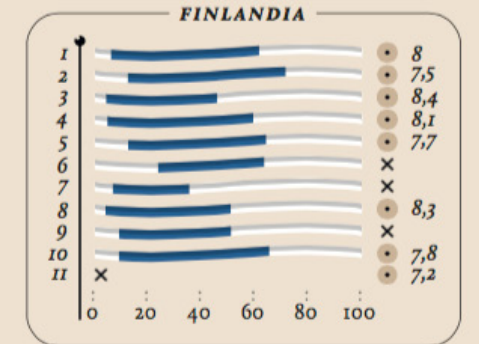
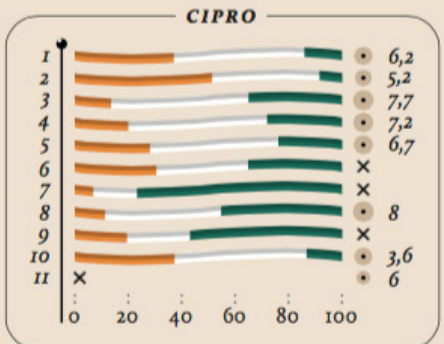
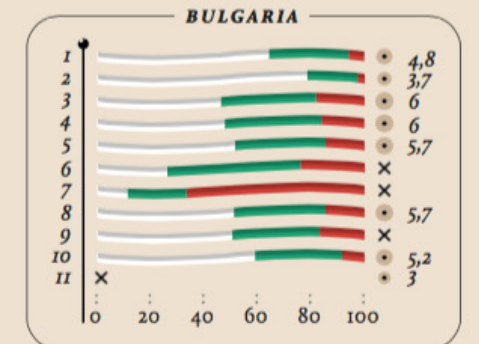
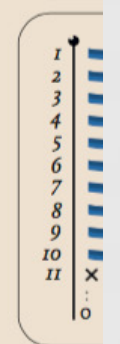
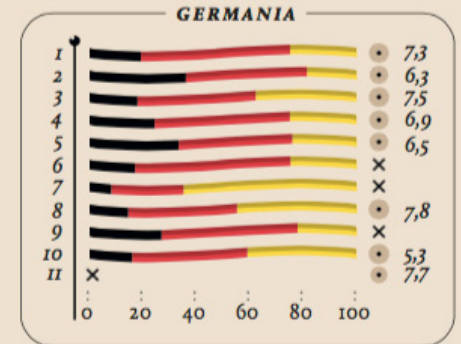
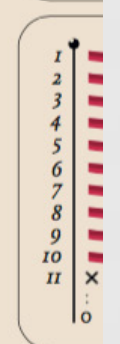
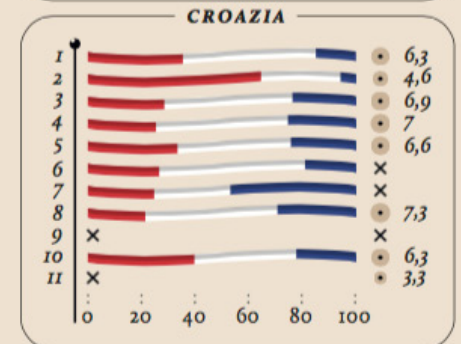
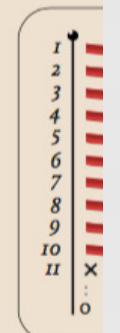
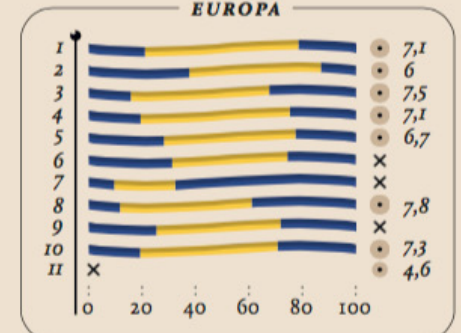
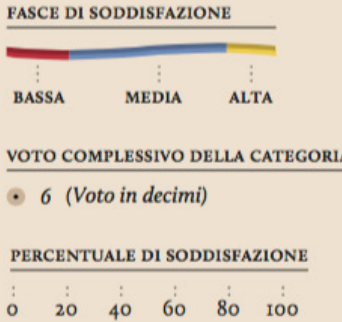

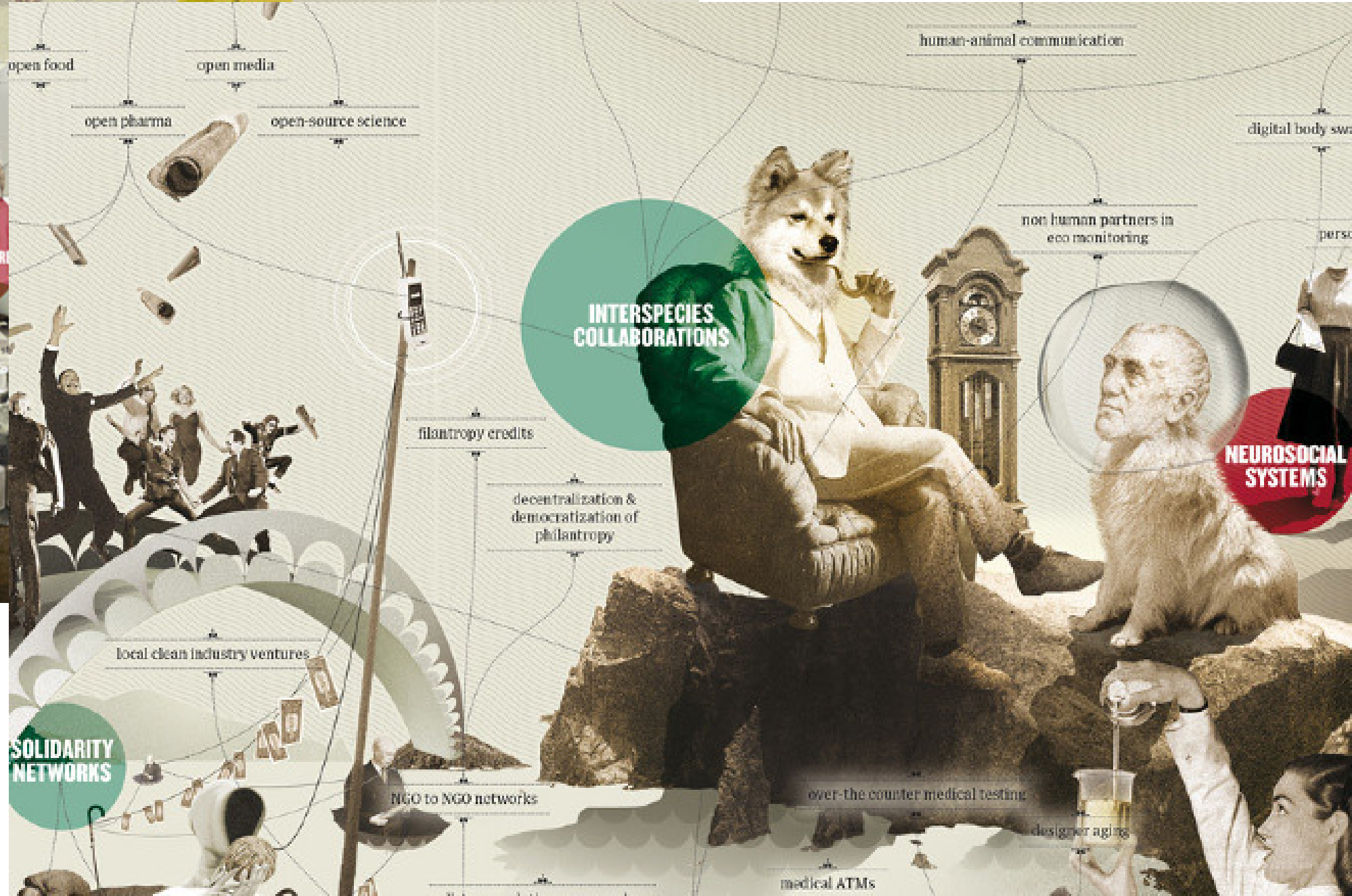
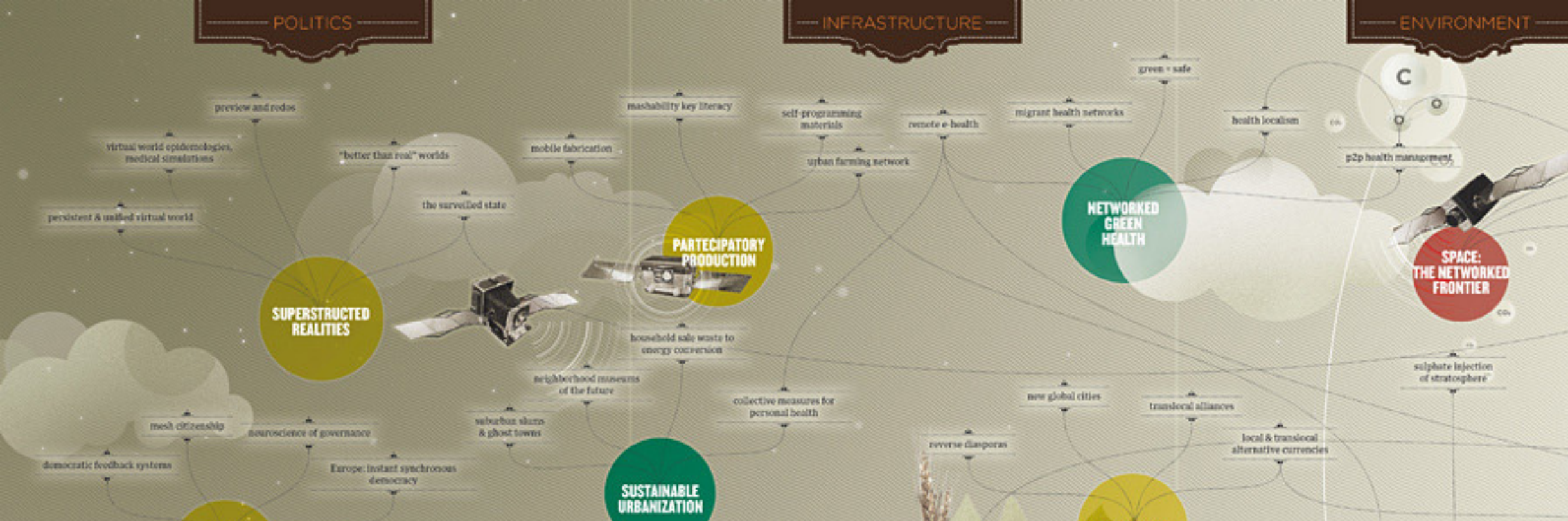

**How to visualize relational, subjective, temporal, ephemeral phenomena?**